



ANGLE BROOM

OPERATING & MAINTENANCE MANUAL



SALES@NORMENG.COM.AU • 07 3376 3177 • WWW.NORMENG.COM.AU

BRISBANE

PH: 07 3376 3177
FAX: 07 3376 3201
787 BOUNDARY ROAD
DARRA QLD 4076

MELBOURNE

PH: 03 9775 1965
FAX: 03 9786 9102
2/45 FRANKSTON GARDENS DRIVE
CARRUM DOWNS VIC 3201

Contents

1	Introduction	1
2	Safety Definitions: Terms and Symbols.....	2
3	Safety Instructions	3
3.1	Important Points	5
4	Predelivery	6
4.1	Check Pickup Fit	6
4.2	Check Range of Motion.....	6
4.3	Check Hydraulic Hoses	7
4.4	Check Electrical Connection	7
4.5	Hydraulic Motor Running-in.....	7
5	Assembly Instructions	8
5.1	Hitching Up the Angle Broom.....	8
5.2	Removing the Angle Broom	9
6	Operating Instructions	10
6.1	Specified Operations and Limitations.....	10
6.2	Brush Rotation Direction	11
7	Maintenance and Care.....	12
7.1	Hydraulics.....	12
7.2	Prior to Use	12
7.3	Routine Inspection (Every 12 Weeks).....	13
7.4	Greaseable Points.....	13
7.5	Replacing the Brush.....	14
8	Risk Assessment	16
9	Parts.....	23
9.1	Ordering Parts	23
9.1.1	Reference Information.....	23
10	Parts List	24
11	Appendices.....	32

11.1	Safety Sign Location	32
12	Warranty	33
12.1	Definition	33
12.2	Warranty	33

1 INTRODUCTION

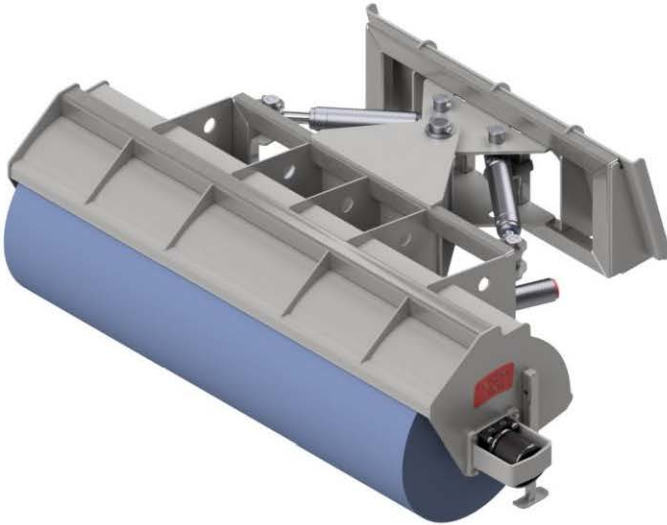

Angle Broom

Congratulations on purchasing a Norm Engineering Pty Ltd attachment. We have designed this angle broom for a long, productive, and safe life. Your attachment will provide you with years of service provided regular maintenance and correct usage is applied.

This manual offers a guide on how to safely assemble, mount, operate and maintain your angle broom. While the manual attempts to cover most situations, there are many unforeseen risks and events that are not included due to the capability of the angle broom. On this basis the owner and/or operator must determine if this attachment is suited for a particular purpose.

Norm Engineering Pty Ltd can accept no responsibility or liability for how you operate your equipment: we can only provide warning notes and safety precautions in relation to the standard operation of the angle broom.

The illustrations and data used in this manual were current at the time of printing but due to possible engineering and/or production changes, this product may vary slightly. Norm Engineering Pty Ltd reserves the right to redesign and/or change components as may be necessary without notification.

2 SAFETY DEFINITIONS: TERMS AND SYMBOLS

We will use the ANSI Z535.4-2011(R2017) standard for the definitions of signal words as described in conjunction with colours red, orange, and yellow. These are used with the Safety Alert Symbol:

- **Signal word:** Are defined as the words used in the signal word panel. The signal words for hazard alerting signs are “DANGER”, “WARNING”, and “CAUTION”. Safety notice signs use the signal word “NOTICE”. Safety instruction signs use signal words that are specific to the situation.
- **DANGER:** Indicates a hazardous situation, which, if not avoided, **will** result in death or serious injury. This signal word is to be limited to the most extreme situations. (White letters on a red background) 
- **WARNING:** Indicates a hazardous situation, which, if not avoided, **could** result in death or serious injury. (Black letters on an orange background) 
- **CAUTION:** Indicates a hazardous situation, which, if not avoided, **could** result in minor or moderate injury. (Black letters on a yellow background) 
- **NOTICE:** Indicates information considered important, but **not** hazard-related (e.g., messages relating to property damage). (White letters on a blue background) 
- **SAFETY INSTRUCTIONS:** Indicates a type of safety sign, where specific **safety-related instructions** or **procedures** are described. More definitive signal words are encouraged, where practical (e.g., SAFE SHUTDOWN PROCEDURE, SAFE OPERATING PROCEDURE). (White letters on a green background) 

3 SAFETY INSTRUCTIONS



WARNING

Obey all the safety instructions listed in this section and throughout this manual. Failure to follow instructions could result in death or serious injury.

NOTICE

Before attempting any type of assembly operation, maintenance, or other work on or near this product:

- READ and COMPLETELY UNDERSTAND:
 - This manual,
 - The manuals provided with the power unit being used with this attachment.
- Read and understand all safety signs associated with the equipment being used.
- Know all your controls and know how to quickly stop all power unit movement, the attachment movement, and the engine in case of an emergency.

SAFETY IS YOUR RESPONSIBILITY AS THE OPERATOR OF THE EQUIPMENT

Inappropriate and/or irresponsible use of an angle broom may cause serious injury and trauma. The operator must have all relevant industry competencies, qualifications, certificates and/or licenses.

The operator must understand their responsibilities under the relevant acts and regulations of the governing body. Failure to comply with your legal obligations under the act may result in prosecutions against you.

As the equipment operator you are responsible to familiarise yourself, and anyone else who will assemble, operate, maintain, or work around this product with the safety information contained within this manual. You must make certain that all operators and maintenance personnel have a complete understanding of the full and exact contents of this manual and those of the power unit.

There are usually specific precautions and steps in the power unit operating manual to be taken to ensure your safety prior to engaging the attachment.

Conduct a job site survey during the planning phase of any construction project to identify potential hazards and develop and implement appropriate control measures to protect workers.

Accidents are preventable if the equipment operator is careful and responsible. No accident prevention program can be successful unless there is a wholehearted commitment and cooperation of the person who is directly responsible for the operation of the equipment.

Make sure anyone who will be installing, maintaining, repairing, removing, and/or storing this product applies the Workplace Health and Safety Act requirements. This includes ensuring that the person has been instructed in the safe operation of this product and of the power unit to which this attachment is likely to be attached.

Know and follow good work practices, some of these include:

- To optimise the physical environment such as having a well-lit, level surface that is clean and dry to work on.
- Use properly grounded, test and tagged electrical outlets and tools.
- Use the right tool for the job at hand.
- Make sure that your tools are in good condition for performing the required function.
- When using tools, wear the protective equipment specified by the tool manufacturer (hardhat, safety glasses, work gloves, protective shoe...)
- When the attachment has been out in the sun, remember to wear protective gloves as the metal will be hot to touch.
- Before starting, know the job duration, job complexity, and best procedure.
- Ensure workers have the capacity to do the job.
- Check that all hazards have been identified and control measures implemented.
- Clear communication so everyone present knows what is happening.
- Clear emergency stop procedure so there is no confusion in an emergency.
- Ensure the use of tyre stoppers and securing framework to stop the plant and plant attachment moving during maintenance.

3.1 IMPORTANT POINTS

When your power unit is used during any type of assembly, operation, maintenance, or other work on or near this product:

- Before leaving the operator's station or before beginning any type of work on this product, lower this product to the ground, apply your power unit's parking brake, stop the engine, remove the starter key, wait for all moving parts to stop, and then relieve all pressure in the hydraulic lines. Refer to your power unit's operating manual for instructions on preparing the equipment for hitching up an attachment and relieving hydraulic pressure in lines.
- Know your power unit's safe lifting and operating capacity and the weight of this product. (Check the parent machines operator manuals for safe operating limits).
- Only allow the operator to be around the power unit or this product when either is in motion. Ensure work area is clear of all personnel.
- Apply all safety guidelines in relation to the operator and the equipment.
- Only operate controls from the operator's station.
- Maintain operator presence at all times when the engine is running, or the product is raised on the power unit.
- Reduce speeds when additional weight and width need to be considered especially over rough ground.
- Consider the operating environment if dust is a concern reduce the machine speed.
- Whilst in motion keep the product close to the ground and under control.

4 PREDELIVERY

The following steps should be performed when fitting this attachment to a power unit for the first time. Failure to perform these checks may lead to damage of the attachment, the power unit and be a risk to safety. Warranty claims that arise as a result of skipping these steps may be challenged.

4.1 CHECK PICKUP FIT

Perform '5.1 Hitching Up the Angle Broom' to check how the attachment fits the coupler. Check for the following:

- Do the pins lock?
- Is it a snug fit?

4.2 CHECK RANGE OF MOTION

Carefully go through the attachment and parent machines full range of motion together. If unexpected contact occurs, contact Norm Engineering to discuss. Due to the capabilities of this product some contact with the machine may be unavoidable. In this case place the warning sticker provided on the attachment and inform the owner/operator.



4.3 CHECK HYDRAULIC HOSES

If you are unsure how to route the hydraulic hoses, contact Norm Engineering. Connect hoses and once again thoroughly check full range of motion to make sure:

- They **DON'T** pull tight.
- They **DON'T** have excessive length.

If the hose length is not correct, call Norm Engineering first for assistance.

4.4 CHECK ELECTRICAL CONNECTION

We take every opportunity to supply the attachment as a plug and play solution with a factory matching electrical connector, but unfortunately this is not possible for all machines.

Norm Engineering recommends using a certified and qualified electrical technician to perform these modifications to the parent machine. For additional information refer to section '12 Warranty'.

If wiring is required Norm Engineering recommends connecting the attachment via a relay to a momentary push button on the opposite control switch to the one that operates the standard flow auxiliary hydraulics. Wire polarity is not important and max current draw is under 5 Amps.

4.5 HYDRAULIC MOTOR RUNNING-IN

To maximise the life of the unit, it must be run in for a period. To carry out the running in procedure, suspend the brush just off the ground in a horizontal working position. Ensure there are no bystanders within the nominated radius as defined in the risk assessment completed prior to commencing any works.

Operate the motor at 30% of rated pressure for 20 minutes in each direction before application of full operating load.

5 ASSEMBLY INSTRUCTIONS



WARNING

Obey all instructions listed in this section of the manual. Failure to follow the instructions listed below could lead to serious injuries.

For any assistance with the following processes, please contact Norm Engineering.

5.1 HITCHING UP THE ANGLE BROOM



DANGER

All safety precautions pertaining to both the power unit and the angle broom need to be followed. Sufficient planning should be made prior to any work commencing in case of an emergency situation.

Step one: Before beginning any work on this product, lower the product to the ground on a firm level surface that is large enough to accommodate this product, the power unit and all workers involved in the hitching up the angle broom.

Step two: Refer to your power unit's operating manual for instructions on hitching up this attachment. Visually inspect to ensure the attachment is fully engaged to the power unit hitch.

Step three: Engage the locking mechanism. A visual inspection should be performed to confirm all locking systems are secured. Give the angle broom a few short sharp movements close to the ground to ensure it is engaged.

Step four: Rest the attachment on the ground and refer to the power unit operating manual to release the pressure in the hydraulic system.

Step five: Connect the hydraulic couplings and electrical connectors on the angle broom to the power unit couplings following all safety precautions specified in the power units operating manual.

Step six: Remove the locking pins from the storage legs before raising them and securing them into place with the same locking pins.

Step seven: Start the machine and cycle the angle broom cylinder and hydraulic motor several times before taking it near other personnel.

5.2 REMOVING THE ANGLE BROOM

DANGER

All safety precautions pertaining to both the power unit and the angle broom need to be followed. Sufficient planning should be made prior to any work commencing in case of an emergency situation.

Step one: Remove the machine from anywhere near other personnel and onto a firm level surface large enough to safely accommodate this product, the power unit and all workers involved in removing the angle broom.

Step two: Remove the locking pins from the storage legs before lowering them and securing them into place with the same locking pins.

Step three: Rest the angle broom on the ground.



Step four: Disconnect the attachments hydraulic couplings and electrical connectors from the power unit following all safety precautions. Refer to your power unit's operating manuals.

Step five: Disengage the locking mechanism. A visual inspection should be performed to make sure the angle broom is fully disengaged.

Step six: Refer to your power unit's operating manual for instructions on removing the attachment and confirm the hitch is fully disengaged from the angle broom.

Step seven: Store safely.

6 OPERATING INSTRUCTIONS

⚠ DANGER When using the angle broom, ensure all personnel wear appropriate personal protective equipment at all times. All personnel must stand well clear of the angle broom during operation. Contact with the attachment, parent machine or flying debris and dust could cause injury to personnel working in the vicinity of the machine.

6.1 SPECIFIED OPERATIONS AND LIMITATIONS

The angle broom is designed to clear long sections of level ground of loose soil and small debris. The hydraulic tilting system allows the broom to push the loose soil and small debris to either side of the machine.

⚠ CAUTION

- **WHEN** sweeping material forward, reduce motor sweep to minimise dust and debris kick up.
- **ENSURE** no one is in front of the sweeper.
- **IF** dust kick up is excessive stop sweeping and reassess method.

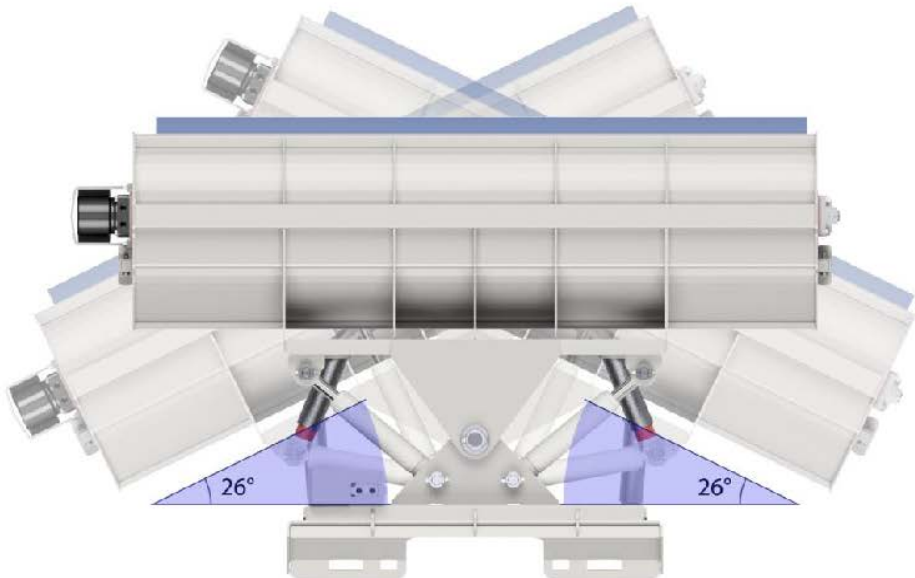

⚠ DANGER

- **NEVER** use the angle broom as a lifting point.
- **NEVER** use the angle broom to lift or carry people.

⚠ WARNING

- **MISUSE** may damage the attachment or lead to injury and trauma.
- **ENSURE** an appropriately sized angle broom is used for your machine.

⚠ CAUTION

- **OVERALL** width of the angle broom does vary when tilted.
- **ENSURE** you travel at a slow speed appropriate to prevent causing damage if an unseen obstacle is hit.

NOTICE

- **USE** low engine speeds to maximizes brush life.
- **NEVER** use the angle broom to pull or push over objects.
- **NEVER** run the broom's brush into large piles of soil and debris.
- **NEVER** reverse the broom rotation while the brush is still turning.
- **ALWAYS** engage the brush with engine at idle and increase to operating speed. When stopping brush rotation, **BE SURE** to return engine to idle before disengaging oil flow.

6.2 BRUSH ROTATION DIRECTION

When sweeping the brush should always be rotated so that material is pushed in front of the machine. This prevents loose soil and small debris from being flung back towards the operator. For efficient cleaning and a long brush life the operator should always attempt to keep 10-20mm of the brush engaged into the sweeping surface.

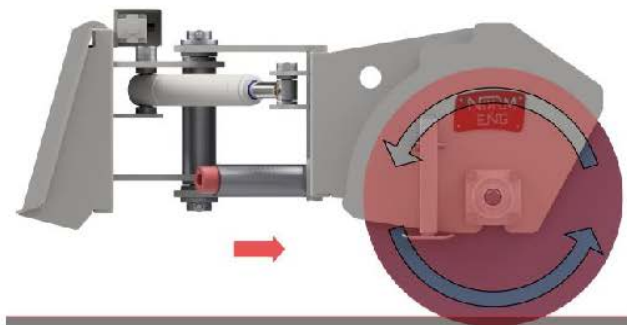

7 MAINTENANCE AND CARE

WARNING

Before commencing maintenance, place the attachment on level ground. Ensure enough area to perform maintenance on the attachment. Follow 5.2 Removing the Angle Broom.

WARNING

After maintenance is complete, follow 5.1 Hitching Up the Angle Broom.

7.1 HYDRAULICS

WARNING

Read and understand all safety requirements prior to beginning any maintenance to any hydraulic connections. It is imperative that if there are any fittings, repairs etc. required these must be conducted by a fully certified and qualified hydraulics fitter.

7.2 PRIOR TO USE

Prior to use, the angle broom shall be visually inspected to verify the attachment is in an operational state. The inspection will check for:

- Signs of wear, including corrosive and abrasive wear.
- Markings are legible.
- Welds are not damaged, cracked or worn.
- Hydraulic hoses, fittings and cylinders are in good conditions with no leaks.
- All fasteners are in place and correctly torqued.
- Inspect the wear of the brush.
- Grease all fittings – this needs to be performed on a daily basis.

7.3 ROUTINE INSPECTION (EVERY 12 WEEKS)

Routine inspections should include but is not limited to the following:

- Fittings, hoses, and hydraulics must be checked to ensure there are no leaks.
- Pins and bushes should be inspected for signs of excessive wear and replaced before the wear damages the structure of the angle broom.
- Inspect the attachment for wear, particularly around the brush, and seek advice on replacement if wear is excessive.
- Check to ensure attachment markings are legible.
- Organise for a certified and qualified hydraulics fitter to inspect and replace hydraulic hoses and seals in the hydraulic parts as necessary. For additional information refer to section '12 Warranty'.

7.4 GREASEABLE POINTS

The location of all six greaseable points can be found in the diagram below. As part of 7.2 Prior to Use, ensure these points have been greased prior to use.

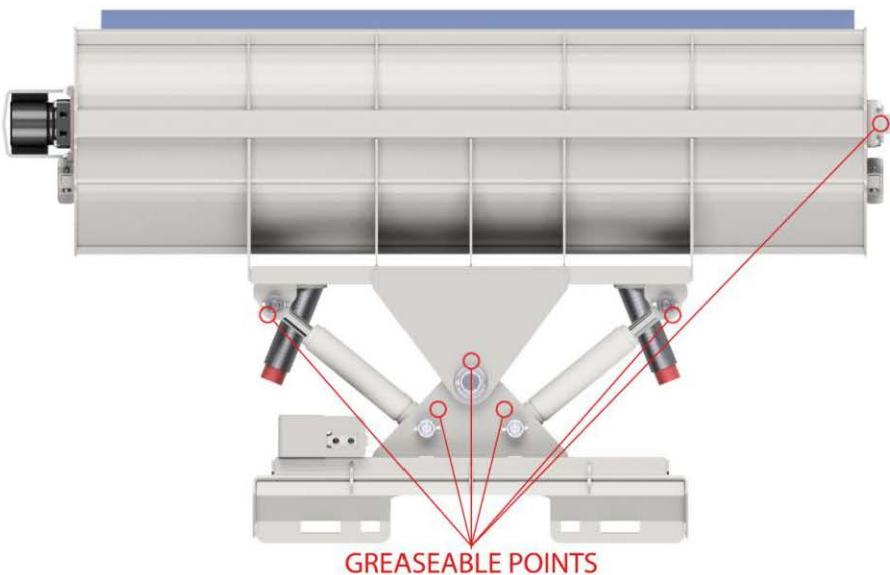

7.5 REPLACING THE BRUSH



- **DO NOT** use blocking material that could collapse or shift positions.

- **DO NOT** use wood or steel blocking that shows any signs of material decay.
- **DO NOT** use blocking that is warped, twisted, or tapered.
- **ENSURE** a safe working environment prior to replacing any sweeper components.

Step one: Lower the angle broom onto sufficient blocking to replace the brush before following '5.2 Removing the Angle Broom.'

Step two: Unbolt and remove the motor guard.



Sweeper brush on the motor side will swing down as the motor unit is removed.

Step three: Support the brush and driveshaft to prevent it from suddenly swinging down when the motor unit is removed.

Step four: Unbolt the hydraulic motor and remove the motor with drive block.

Step five: Lower the motor side of the brush.

Step six: Take off the brush stopper and slide the old brush off the drive shaft.

Step seven: Slide the new brush onto the driveshaft and cap with brush stopper.

Step eight: Lift new brush assembly back up into place and insert the hydraulic motor unit and drive block.

Step nine: Bolt hydraulic motor and motor guard back into place.

Step ten: Follow '5.1 Hitching Up the Angle Broom' and ensure the new brush spins freely.



8 RISK ASSESSMENT

Assessment Team: Norman Pesch, John Pesch, Sam Ramsden

Date of Assessment: 13/04/2022

Manufacturer: Norm Engineering Pty Ltd

Location: Brisbane

Contact Person: Norman Pesch

Attachment: Angle Broom

Weight: 240-600kg

Intended use: Road Cleaning

Construction material: Steel

Air Operated: NO

Hydraulic Operated: YES

Manually operated: NO

NOTE: When assessing Risk, you MUST consider the following

Inherent Risk:

(Risk before ANY controls). I.e., Before guarding / safety features are fitted.

Residual Risk:

(Risk after controls are fitted). I.e., after guarding / safety features are fitted.

Non Standard Operating Risk:

(Cleaning, Maintenance). I.e., What other risks can these tasks create.

Predictable Misuse:

I.e., What risks could occur due to misuse of the attachment.

HAZARD INFORMATION

The plant must be assessed against the hazards listed for the probability of harm to operators working in close proximity and the environment.

Probability

- A – Common or repeating occurrence
- B – Known to occur or “It has happened”
- C – Could occur, “I’ve heard of it happening”
- D – Not likely to occur
- E – Practically impossible

Consequence

- 1 – Catastrophic – Fatalities
- 2 – Major – Major injury, LTI
- 3 – Moderate – Minor Injury
- 4 – Minor – First aid, slight injury
- 5 – Insignificant – Minimal risk of injury

	A	B	C	D	E
1	H	H	H	S	S
2	H	H	S	S	M
3	H	H	S	M	L
4	H	S	M	L	L
5	S	S	M	L	L

H = High

S = Significant

M = Medium

L = Low

Entanglement:

<p>Can anyone's hair, clothing gloves, necktie, jewellery, rags, and other materials become entangled with moving parts of plant, or materials in motion?</p> <p>People in close proximity to the plant and plant attachment during operation have the ability to become entangled, i.e., HYD. cylinders, broom, and pivoting section.</p>	Yes	No	A	<input type="checkbox"/>	1	<input type="checkbox"/>	High Significant Medium Low	<input type="checkbox"/>
	<input checked="" type="checkbox"/>	<input type="checkbox"/>	B	<input type="checkbox"/>	2	<input checked="" type="checkbox"/>		<input checked="" type="checkbox"/>
			C	<input type="checkbox"/>	3	<input type="checkbox"/>		<input type="checkbox"/>
			D	<input checked="" type="checkbox"/>	4	<input type="checkbox"/>		<input type="checkbox"/>
			E	<input type="checkbox"/>	5	<input type="checkbox"/>		<input type="checkbox"/>

Crushing:

<p>Can anyone be crushed due to falling, uncontrolled or unexpected movement of plant attachment or its load, lack of capacity to slow, stop or immobilise the plant, tipping or rolling over, parts of plant attachment collapsing, contact with moving parts during testing, inspection, maintenance, cleaning, or repair, thrown off, under or trapped between plant and materials or fixed structures?</p> <p>People in close proximity to the plant and plant attachment during operation could be crushed if the operator is not being sufficiently observant, or control over the plant is lost.</p>	Yes	No	A	<input type="checkbox"/>	1	<input type="checkbox"/>	High Significant Medium Low	<input type="checkbox"/>
	<input checked="" type="checkbox"/>	<input type="checkbox"/>	B	<input type="checkbox"/>	2	<input checked="" type="checkbox"/>		<input type="checkbox"/>
			C	<input type="checkbox"/>	3	<input type="checkbox"/>		<input type="checkbox"/>
			D	<input type="checkbox"/>	4	<input type="checkbox"/>		<input type="checkbox"/>
			E	<input checked="" type="checkbox"/>	5	<input type="checkbox"/>		<input type="checkbox"/>

Cutting, Stabbing, Puncturing:

<p>Can anyone be cut, stabbed, or punctured by coming in contact with moving plant or parts, sharp or flying objects, work pieces ejected, work pieces disintegrated, or other factors not mentioned?</p> <p>People can be cut, stabbed, or punctured by coming into contact with projectiles flung from the rotating broom.</p>	Yes	No	A	<input type="checkbox"/>	1	<input type="checkbox"/>	High Significant Medium Low	<input type="checkbox"/>
	<input checked="" type="checkbox"/>	<input type="checkbox"/>	B	<input type="checkbox"/>	2	<input checked="" type="checkbox"/>		<input checked="" type="checkbox"/>
			C	<input type="checkbox"/>	3	<input type="checkbox"/>		<input type="checkbox"/>
			D	<input checked="" type="checkbox"/>	4	<input type="checkbox"/>		<input type="checkbox"/>
			E	<input type="checkbox"/>	5	<input type="checkbox"/>		<input type="checkbox"/>

Striking:

<p>Can anyone be struck by moving objects due to plant or work pieces being ejected or disintegrated, mobility, uncontrolled or unexpected movement of the plant or other factors?</p> <p>People in close proximity to the plant and plant attachment during operation could be seriously hurt if they came into contact with the plant, or plant attachment if the operator is not being sufficiently observant, or control over the plant is lost.</p>	Yes	No	A	<input type="checkbox"/>	1	<input type="checkbox"/>	High Significant Medium Low	<input checked="" type="checkbox"/>
	<input checked="" type="checkbox"/>	<input type="checkbox"/>	B	<input checked="" type="checkbox"/>	2	<input checked="" type="checkbox"/>		<input type="checkbox"/>
			C	<input type="checkbox"/>	3	<input type="checkbox"/>		<input type="checkbox"/>
			D	<input type="checkbox"/>	4	<input type="checkbox"/>		<input type="checkbox"/>
			E	<input type="checkbox"/>	5	<input type="checkbox"/>		<input type="checkbox"/>

Slipping, Tripping, Falling:

<p>Can anyone using the plant or in the vicinity of the plant, slip, trip or fall due to the working environment or other factors? poor housekeeping, dust on the floor around machines, slippery or uneven work surfaces or lack of guardrails.</p> <p>People standing on the plant attachment could slip or fall from it.</p>	Yes	No	A	<input type="checkbox"/>	1	<input type="checkbox"/>	High Significant Medium Low	<input type="checkbox"/>
	<input checked="" type="checkbox"/>	<input type="checkbox"/>	B	<input type="checkbox"/>	2	<input type="checkbox"/>		<input type="checkbox"/>
			C	<input type="checkbox"/>	3	<input checked="" type="checkbox"/>		<input type="checkbox"/>
			D	<input checked="" type="checkbox"/>	4	<input type="checkbox"/>		<input type="checkbox"/>
			E	<input type="checkbox"/>	5	<input type="checkbox"/>		<input type="checkbox"/>
								<input type="checkbox"/>

Shearing:

<p>Can anyone's body parts be cut off between two parts of the plant, or between a part of the plant and a work piece or structure? For example, on a metal guillotine can a finger fit under the guard.</p> <p>People not following SOP's or plant guidelines could become injured from misuse or working in the vicinity of the plant and plant attachment.</p>	Yes	No	A	<input type="checkbox"/>	1	<input type="checkbox"/>	High Significant Medium Low	<input type="checkbox"/>
	<input checked="" type="checkbox"/>	<input type="checkbox"/>	B	<input type="checkbox"/>	2	<input checked="" type="checkbox"/>		<input type="checkbox"/>
			C	<input type="checkbox"/>	3	<input type="checkbox"/>		<input type="checkbox"/>
			D	<input checked="" type="checkbox"/>	4	<input type="checkbox"/>		<input type="checkbox"/>
			E	<input type="checkbox"/>	5	<input type="checkbox"/>		<input type="checkbox"/>
								<input type="checkbox"/>

Friction:

<p>Can anyone be burnt due to contact with moving parts or surfaces of the plant, or material handled by the plant? For example, on the grinder is there more than 1 mm gap between the tool rest and the wheel?</p> <p>People could be burned by rotating parts if correct SOP's are not followed.</p>	Yes	No	A	<input type="checkbox"/>	1	<input type="checkbox"/>	High Significant Medium Low	<input type="checkbox"/>
	<input checked="" type="checkbox"/>	<input type="checkbox"/>	B	<input type="checkbox"/>	2	<input type="checkbox"/>		<input type="checkbox"/>
			C	<input type="checkbox"/>	3	<input checked="" type="checkbox"/>		<input type="checkbox"/>
			D	<input checked="" type="checkbox"/>	4	<input type="checkbox"/>		<input type="checkbox"/>
			E	<input type="checkbox"/>	5	<input type="checkbox"/>		<input type="checkbox"/>
								<input type="checkbox"/>

High Pressure Fluid:

<p>Can anyone come into contact with fluids under high pressure, due to plant failure or misuse of the plant?</p> <p>The plant attachment utilizes the plants high pressure hydraulic system, if a failure occurs it is possible to come into contact with high pressure fluid.</p>	Yes	No	A	<input type="checkbox"/>	1	<input type="checkbox"/>	High Significant Medium Low	<input type="checkbox"/>
	<input checked="" type="checkbox"/>	<input type="checkbox"/>	B	<input type="checkbox"/>	2	<input checked="" type="checkbox"/>		<input type="checkbox"/>
			C	<input type="checkbox"/>	3	<input type="checkbox"/>		<input type="checkbox"/>
			D	<input checked="" type="checkbox"/>	4	<input type="checkbox"/>		<input type="checkbox"/>
			E	<input type="checkbox"/>	5	<input type="checkbox"/>		<input type="checkbox"/>
								<input type="checkbox"/>

Electrical:

<p>Can anyone be injured by electrical shock or burnt due to damaged or poorly maintained leads or switches, water near electrical equipment, working near or contact with live electrical conductors, lack of isolation procedures or the factors not mentioned? For example, are any switches broken, is there a red emergency stop? Can each machine be locked off for repairs?</p> <p>The plant attachment utilizes auxiliary electrical connection to operate a diverter valve on the attachment. Wear or improper installation of electrical components could lead to damage.</p>	Yes	No	A	<input type="checkbox"/>	1	<input type="checkbox"/>	High Significant Medium Low	<input type="checkbox"/>
	<input checked="" type="checkbox"/>	<input checked="" type="checkbox"/>	B	<input type="checkbox"/>	2	<input type="checkbox"/>		<input type="checkbox"/>
			C	<input checked="" type="checkbox"/>	3	<input type="checkbox"/>		<input type="checkbox"/>
			D	<input type="checkbox"/>	4	<input checked="" type="checkbox"/>		<input type="checkbox"/>
			E	<input type="checkbox"/>	5	<input type="checkbox"/>		<input type="checkbox"/>
								<input type="checkbox"/>

Dust:

<p>Can anyone suffer ill health or injury due to exposure to dust? For example, cutting, living silica Lack of vision – External influences causing the dust. Plant operation causing the dust.</p> <p>Depending on the operation location of the plant and plant attachment dust being a nuisance could be a factor.</p>	Yes	No	A	<input type="checkbox"/>	1	<input type="checkbox"/>	High Significant Medium Low	<input type="checkbox"/>
	<input checked="" type="checkbox"/>	<input type="checkbox"/>	B	<input type="checkbox"/>	2	<input checked="" type="checkbox"/>		<input checked="" type="checkbox"/>
			C	<input checked="" type="checkbox"/>	3	<input type="checkbox"/>		<input type="checkbox"/>
			D	<input type="checkbox"/>	4	<input type="checkbox"/>		<input type="checkbox"/>
			E	<input type="checkbox"/>	5	<input type="checkbox"/>		<input type="checkbox"/>

Noise:

<p>Can anyone suffer hearing discomforts while the plant is in use? For example, the plant is noisy, and it is difficult to hear.</p> <p>Depending on the surface the broom is operated on the friction could lead to excessive noise which may cause damage over time.</p>	Yes	No	A	<input type="checkbox"/>	1	<input type="checkbox"/>	High Significant Medium Low	<input type="checkbox"/>
	<input checked="" type="checkbox"/>	<input type="checkbox"/>	B	<input type="checkbox"/>	2	<input type="checkbox"/>		<input type="checkbox"/>
			C	<input type="checkbox"/>	3	<input checked="" type="checkbox"/>		<input checked="" type="checkbox"/>
			D	<input checked="" type="checkbox"/>	4	<input type="checkbox"/>		<input type="checkbox"/>
			E	<input type="checkbox"/>	5	<input type="checkbox"/>		<input type="checkbox"/>

Vibration:

<p>Can anyone suffer injury due to the vibration of the plant?</p> <p>The plant attachment could cause excessive vibration if it is operated whilst damaged or not correctly maintained.</p>	Yes	No	A	<input type="checkbox"/>	1	<input type="checkbox"/>	High Significant Medium Low	<input type="checkbox"/>
	<input checked="" type="checkbox"/>	<input type="checkbox"/>	B	<input type="checkbox"/>	2	<input type="checkbox"/>		<input type="checkbox"/>
			C	<input type="checkbox"/>	3	<input checked="" type="checkbox"/>		<input checked="" type="checkbox"/>
			D	<input checked="" type="checkbox"/>	4	<input type="checkbox"/>		<input type="checkbox"/>
			E	<input type="checkbox"/>	5	<input type="checkbox"/>		<input type="checkbox"/>

Environmental:

<p>Can the plant operation cause an environmental issue? For example – pollution, waste materials, noise.</p>	Yes	No	A	<input type="checkbox"/>	1	<input type="checkbox"/>	High Significant Medium Low	<input type="checkbox"/>
	<input type="checkbox"/>	<input checked="" type="checkbox"/>	B	<input type="checkbox"/>	2	<input type="checkbox"/>		<input type="checkbox"/>
			C	<input type="checkbox"/>	3	<input type="checkbox"/>		<input type="checkbox"/>
			D	<input type="checkbox"/>	4	<input type="checkbox"/>		<input type="checkbox"/>
			E	<input type="checkbox"/>	5	<input type="checkbox"/>		<input type="checkbox"/>

Risk Evaluation

Overall risk category of plant:	High	Significant	Medium	Low
---------------------------------	------	--------------------	--------	-----

Risk Controls

Most Desirable

- | | |
|---|---|
| <p>↓</p> <ul style="list-style-type: none"> • Elimination • Substitution • Engineering Controls • Isolation • Administrative Controls • PPE | <ul style="list-style-type: none"> - The best way to eliminate the risk is to remove the hazard. - Substitute the hazardous plant with a safer part, alternative process. - Design modification, installation of guarding, automation/ventilation. - Isolate the plant, barricades, crossing, bunting, etc. - Permits, clearances, lock out systems, certification. - Short term control measure. |
|---|---|

Least Desirable

Hazard	Controls
Entanglement	<p>Isolation – Ensure the operating and maintenance manual provided with the plant attachment recommends the operator of the plant always follows SOP. The operator must make everybody working in the vicinity of the attachment aware of the dangers and before moving the plant ensure people are safe distance away.</p> <p>PPE – Ensuring all people who will be in the vicinity of the plant attachment during operation be wearing clothes with no loose ends that can become entangled in the plant attachment.</p>
Crushing, Striking	<p>Isolation – Ensure the operating and maintenance manual provided with the plant attachment recommends the operator of the plant always follows SOP. The operator must make everybody working in the vicinity of the attachment aware of the dangers and before moving the plant ensure people are safe distance away.</p> <p>PPE – The use of the correct PPE for the worksite will minimize the damage caused by an incident. A hard hat, steel cap boots and tough worksite clothes as an example.</p> <p>PPE – The use of high visibility PPE will help reduce the case of incidents occurring from impaired vision or operator distraction.</p>
Cutting, Stabbing, Puncturing	<p>Isolation – As the designer, manufacturer, and supplier the operating and maintenance manual that are supplied must include instructions for the safe operation of the attachment. This will help to minimize the risk of cutting, stabbing, or puncturing. This will be focused on ensuring a safe working distance is maintained during operation and putting the responsibility for this on the operator of the plant.</p> <p>PPE – The use of the correct PPE for the worksite will minimize the risk of cutting when working in and around the plant attachment. Eyewear, gloves, tough work clothes, and hard hats will reduce the risk associated with the debris being ejected by the plant attachment.</p>
Slipping, Tripping, Falling	<p>Isolation – The plant attachment has NOT been designed to stand on unless entering or exiting the plant. This will be stated in the operating and maintenance manual. It is the responsibility of the operator to ensure that no persons stand on the plant attachment.</p> <p>PPE – Wearing the correct work boots will reduce chances of slipping.</p>
Shearing	<p>Isolation – Ensure the operating and maintenance manual provided with the plant attachment recommends the operator of the plant always follows SOP. The operator must make everybody working in the vicinity of the attachment aware of the dangers and before moving the plant ensure people are safe distance away.</p> <p>Administrative Controls – A warning sticker should be placed in a visible position on the plant attachment highlighting the potential risk</p>

Friction	PPE – Wearing protective gloves will reduce any damage from touching heated components.
High Pressure Fluid	<p>Engineering Controls – The routing of the hydraulic hoses and the design of the plates which guard the hydraulic cylinders, minimizing the risk of the hydraulic failure and exposure to high pressure fluids.</p> <p>Administrative Controls – The manual will address correct maintenance schedules for the plant attachment hydraulics to reduce the risk associated with hydraulic component failure. Only authorized hydraulics fitters should perform repairs on hydraulic systems.</p> <p>Administrative Controls – A warning sticker should be placed in a visible position on the plant attachment highlighting the potential risk.</p>
Electrical	<p>Engineering Controls – The routing of the electrical cable is designed to minimize the risk of the cable being damaged and exposed wires leading to injury.</p> <p>Administrative Controls – The manual will address correct maintenance schedules for the plant attachment to reduce the risk associated with risk caused by improper maintenance, or installation. Only authorized technicians should perform repairs on electrical components</p>
Dust	<p>Isolation and Administrative Controls – To reduce the hazards associated with dust, the manual should instruct the operator to consider their working environment and operate in a manner to reduce the risk of dust being kicked up. This can be managed by operating at a sensible speed.</p> <p>PPE – If the environment is such that the dust cannot be sufficiently controlled, the onsite supervisor should ensure all workers are wearing the correct PPE.</p>
Noise	PPE – The plant attachment should not generate excessive noise, however the work environment which it is being used in might cause hearing discomfort. The operator and site supervisor should ensure all workers always have the correct hearing protection.
Vibration	Administrative Controls – A regular maintenance schedule will help prevent from issues such as misalignment or uneven wear which causes excessive vibration.

Any Modification to Plant Attachment Voids Risk Assessment

Purchaser and User are required to conduct their own risk assessment to identify hazards prior to use.

This risk assessment does not necessarily cover all possible hazards associated with this product and should be utilized in conjunction with the purchasers and users individual risk assessments to identify all environmental, health, and safety risks associated with specific tasks, locations, and personnel.

9 PARTS

QUALITY BACKUP

*We manufacture 90% of our parts inhouse.
This means we can get your parts to you... quickly.*

9.1 ORDERING PARTS

For ordering parts contact either your dealer or Norm Engineering directly. Contact details are included at the front of this manual. To assist, note the details of your angle broom in the spaces provided under *Section 9.1.1 Reference Information*.

9.1.1 REFERENCE INFORMATION

Always refer to the model and serial number when ordering parts or requesting from you dealer. The serial number for this product is located on the identification place of your angle broom.

Model Number:

.....

Make:

.....

Serial Number:

.....

Date Purchased:

.....

10 PARTS LIST

When ordering replacement parts, please include the following information:

- The machine make and model.
- The serial number on the attachment.
- The item number, as indicated by the following figures and tables.
- Parts with a part number of “.:” indicate a component that varies dependent on machine make and model. A serial number and item number is essential if ordering these parts.

Items numbers with a “R” before the number indicate parts that require specialty tools and some knowledge in fabrication and welding to replace.

20" ANGLE BROOM PARTS LIST

Item	Part Number	QTY	Description	Diagram
1	.:	1	20" ANGLE BROOM – FRONT HALF	1
2	.:	1	20" ANGLE BROOM – REAR HALF	1
3	.:	1	DRIVE SHAFT	1
4	SW093	1	BROOM STOPPER	1
5	AS0033	1	ANGLE BROOM – MOTOR GUARD	1
6	AS20040	2	20" ANGLE BROOM – STORAGE LEG	1
7	C2571	1	RHS 2.5" BORE - 8" STROKE HYD. CYLINDER	1
8	C2570	1	LHS 2.5" BORE - 8" STROKE HYD. CYLINDER	1
9	.:	1	20" POLLY PIN DRIVE BRUSH	1
10	SW347	1	DRIVE BLOCK – 140 LONG T/S 64x64 FIT	1
11	SW349	4	DRIVE BLOCK RUBBER	1
12	ME-18-02NORM	1	SWEEPER HYDRAULIC MOTOR	1
13	UCF208-108	1	MAIN SWEEPER SHAFT BEARING	1
14	-	2	ANGLE BROOM – STOPPER KIT	1
15	PI148	1	CENTRE PIVOT PIN	1
16	-	2	SWING BOTTOM HYDRAULIC CYLINDER PIN	1
17	-	2	SWING TOP HYDRAULIC CYLINDER PIN	1
18	PI149	2	LEG LOCKING PIN	1
19	BU402	2	CENTRE PIVOT HARDENED BUSH	1
20	NS2001	4	3/8" GREASE NIPPLE	1

21	-	4	BOLT KIT – MOTOR GUARD ASSEMBLY	1
22	-	4	BOLT KIT – HYDRAULIC MOTOR	1
23	-	4	BOLT KIT – MAIN SWEEPER SHAFT BEARING	1
24	-	2	BOLT KIT – CENTRE PIVOT PIN	1
25	-	2	BOLT KIT – SWING BTM. HYD. CYLINDER PIN	1
26	-	2	BOLT KIT – SWING TOP HYD. CYLINDER PIN	1
R1	RE030	2	SWING BOTTOM HYD. CYLINDER RETAINER	1
R2	BU136	2	SWING BOTTOM HYD. CYLINDER BUSH	1
R3	RE079	2	SWING TOP HYD. CYLINDER RETAINER	1
R4	BU256	2	SWING TOP HYD. CYLINDER BUSH	1

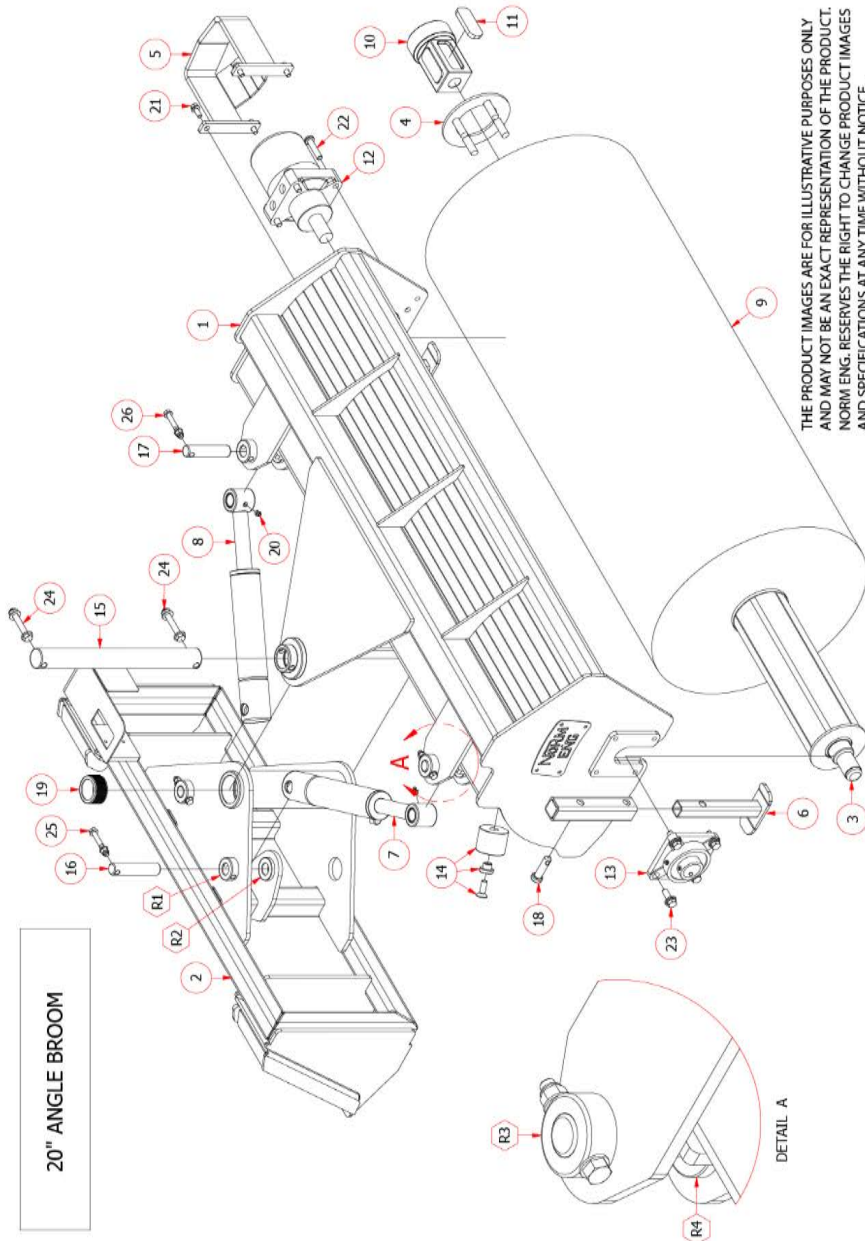

THE PRODUCT IMAGES ARE FOR ILLUSTRATIVE PURPOSES ONLY AND MAY NOT BE AN EXACT REPRESENTATION OF THE PRODUCT. NORM. ENG. RESERVES THE RIGHT TO CHANGE PRODUCT IMAGES AND SPECIFICATIONS AT ANY TIME WITHOUT NOTICE.

20" ANGLE BROOM

24" ANGLE BROOM PARTS LIST

Item	Part Number	QTY	Description	Diagram
1	.:	1	24" ANGLE BROOM – FRONT HALF	2
2	.:	1	24" ANGLE BROOM – REAR HALF	2
3	.:	1	DRIVE SHAFT	2
4	SW093	1	BROOM STOPPER	2
5	AS0033	1	ANGLE BROOM – MOTOR GUARD	2
6	AS20071	2	24" ANGLE BROOM – STORAGE LEG	2
7	C2571	1	RHS 2.5" BORE - 8" STROKE HYD. CYLINDER	2
8	C2570	1	LHS 2.5" BORE - 8" STROKE HYD. CYLINDER	2
9	.:	1	24" POLLY PIN DRIVE BRUSH	2
10	-	1	DRIVE BLOCK - 140 LONG	2
11	SW349	4	DRIVE BLOCK RUBBER	2
12	ME-18-02NORM	1	SWEEPER HYDRAULIC MOTOR	2
13	UCF208-108	1	MAIN SWEEPER SHAFT BEARING	2
14	-	2	ANGLE BROOM – STOPPER KIT	2
15	PI148	1	CENTRE PIVOT PIN	2
16	PI146	2	SWING BOTTOM HYDRAULIC CYLINDER PIN	2
17	PI378	2	SWING TOP HYDRAULIC CYLINDER PIN	2
18	PI149	2	LEG LOCKING PIN	2
19	BU402	2	CENTRE PIVOT HARDENED BUSH	2
20	NS2001	4	3/8" GREASE NIPPLE	2
21	-	4	BOLT KIT – MOTOR GUARD ASSEMBLY	2
22	-	4	BOLT KIT – HYDRAULIC MOTOR	2
23	-	4	BOLT KIT – MAIN SWEEPER SHAFT BEARING	2
24	-	2	BOLT KIT – CENTRE PIVOT PIN	2
25	-	2	BOLT KIT – SWING BTM. HYD. CYLINDER PIN	2
26	-	2	BOLT KIT – SWING TOP HYD. CYLINDER PIN	2
R1	RE030	2	SWING BOTTOM HYD. CYLINDER RETAINER	2
R2	BU136	2	SWING BOTTOM HYD. CYLINDER BUSH	2
R3	RE079	2	SWING TOP HYD. CYLINDER RETAINER	2
R4	BU256	2	SWING TOP HYD. CYLINDER BUSH	2

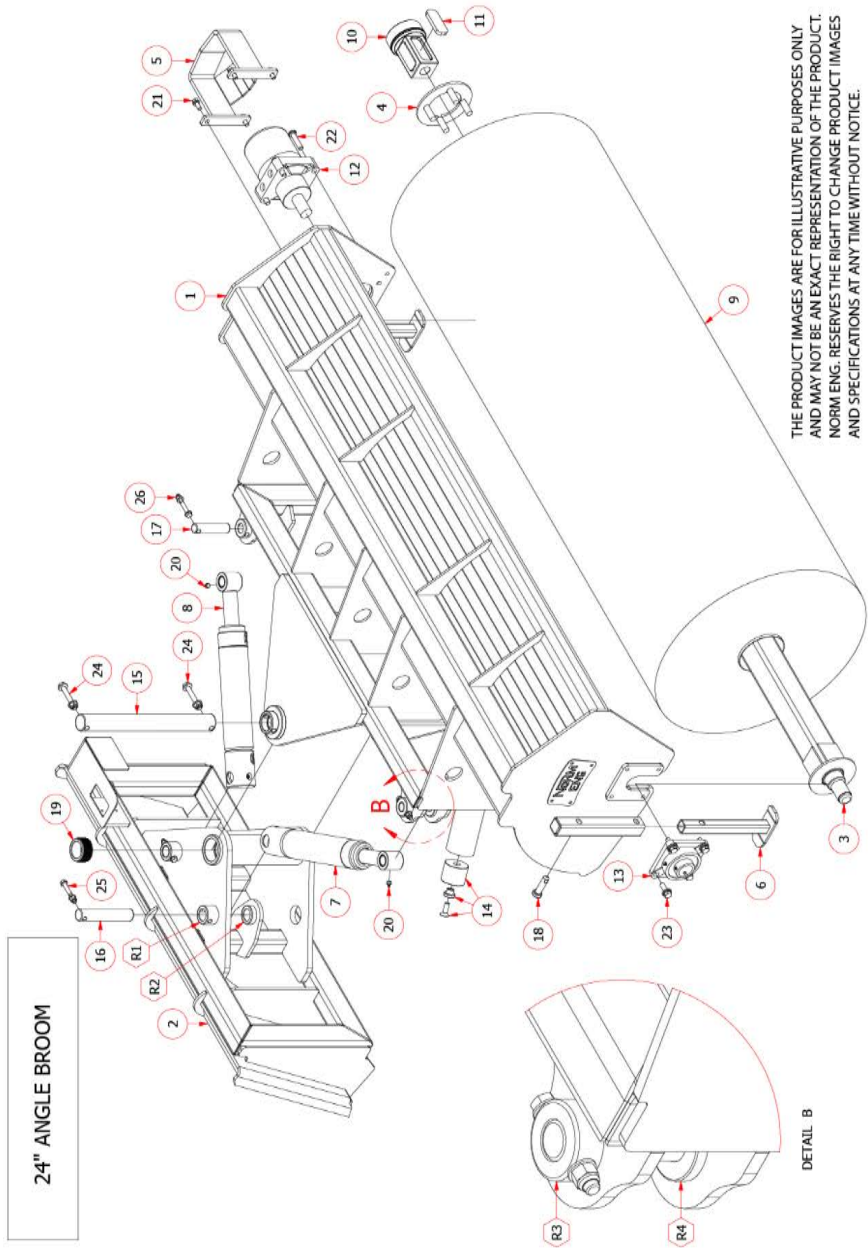

THE PRODUCT IMAGES ARE FOR ILLUSTRATIVE PURPOSES ONLY AND MAY NOT BE AN EXACT REPRESENTATION OF THE PRODUCT. NORM ENG. RESERVES THE RIGHT TO CHANGE PRODUCT IMAGES AND SPECIFICATIONS AT ANY TIME WITHOUT NOTICE.

ANGLE BROOM HYDRAULIC PARTS LIST

Item	Part Number	QTY	Description	Diagram
1	ME-18-02NORM	1	HYDRAULIC SWEEPER MOTOR	3
2	C2571	1	RHS 2.5" BORE - 8" STROKE HYD. CYLINDER	3-4
3	C2570	1	LHS 2.5" BORE - 8" STROKE HYD. CYLINDER	3-4
4	VS280	1	VS280 HYDRAULIC VALVE	3
5	F A13 ½ BSP	1	1/2" FLAT FACE STUCCHI FEMALE	3-4
6	M A13 ½ BSP	1	1/2" FLAT FACE STUCCHI MALE	3-4
7	G-BP-45-1208	2	45 - ADAPTOR - 1/2" BSPPM - 3/4" JICM	3-4
8	B-G-0812	4	ST - ADAPTOR - 1/2" BSPPM - 3/4" JICM	3
9	B-G-0809	2	ST - ADAPTOR - 1/2" BSPPM - 9/16" JICM	3
10	G-N-1214	2	ST - ADAPTOR - 7/8" UNOM - 3/4" JICM	3
11	G-NP-90-0912	4	90 - ADAPTOR - 3/4" UNOM - 9/16" JICM	4
12	G-J-G-090909	2	T-ADAPTOR - 9/16" JICM x 2 - 9/16" JICF	4
13	CF2-M18C	3	18 ID DOUBLE TUBE CLAMP	3
H1	∴	1	HYD. HOSE F-COUPLING TO TOP RHS VALVE	3-4
H2	∴	1	HYD. HOSE M-COUPLING TO TOP LHS VALVE	3-4
H3	∴	1	HYD. HOSE BTM. RHS VALVE TO RHS MOTOR	3-4
H4	∴	1	HYD. HOSE BTM. LHS VALVE TO LHS MOTOR	3-4
H5	∴	1	HYD. HOSE FR. RHS VALVE TO BTM. RHS CYL	3-4
H6	∴	1	HYD. HOSE FR. LHS VALVE TO BTM. LHS CYL	3-4
H7	∴	1	HYD. HOSE BTM. LHS CYL TO TOP RHS CYL	4
H8	∴	1	HYD. HOSE BTM. RHS CYL TO TOP LHS CYL	4

ANGLE BROOM

THE PRODUCT IMAGES ARE FOR ILLUSTRATIVE PURPOSES ONLY AND MAY NOT BE AN EXACT REPRESENTATION OF THE PRODUCT. NORM ENG. RESERVES THE RIGHT TO CHANGE PRODUCT IMAGES AND SPECIFICATIONS AT ANY TIME WITHOUT NOTICE.

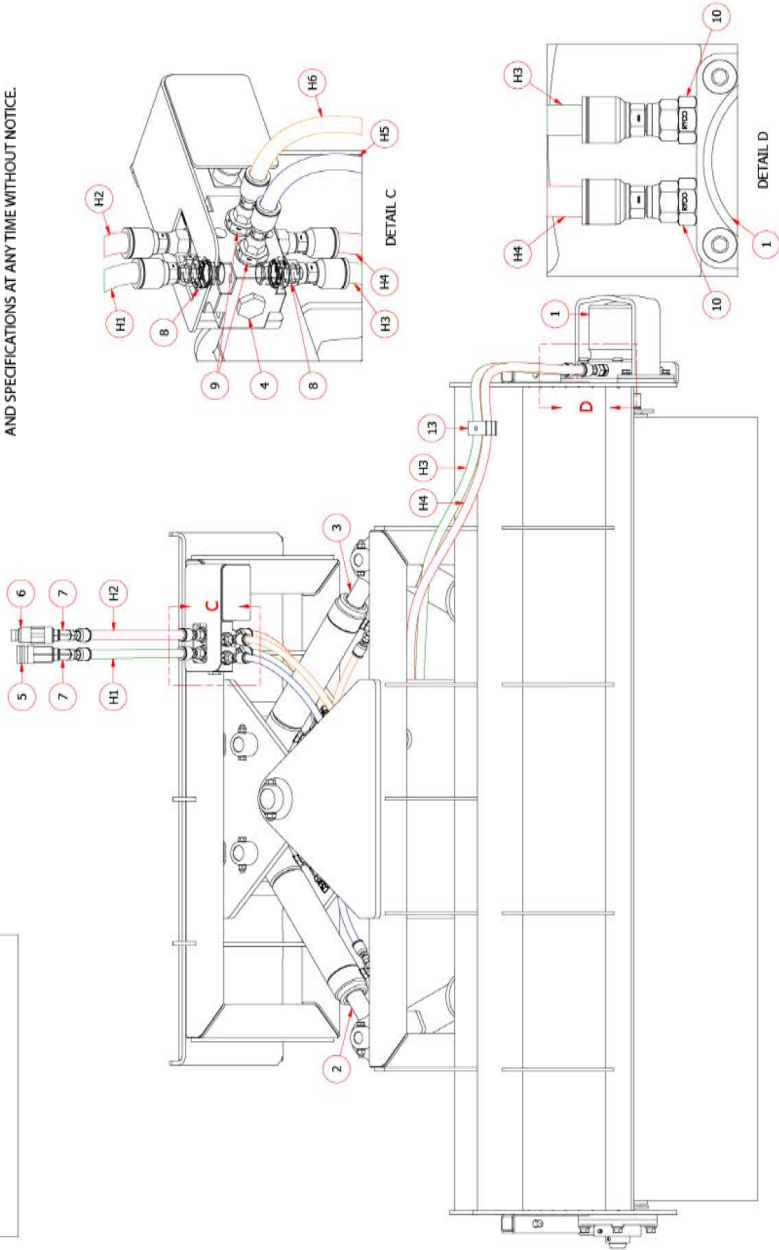
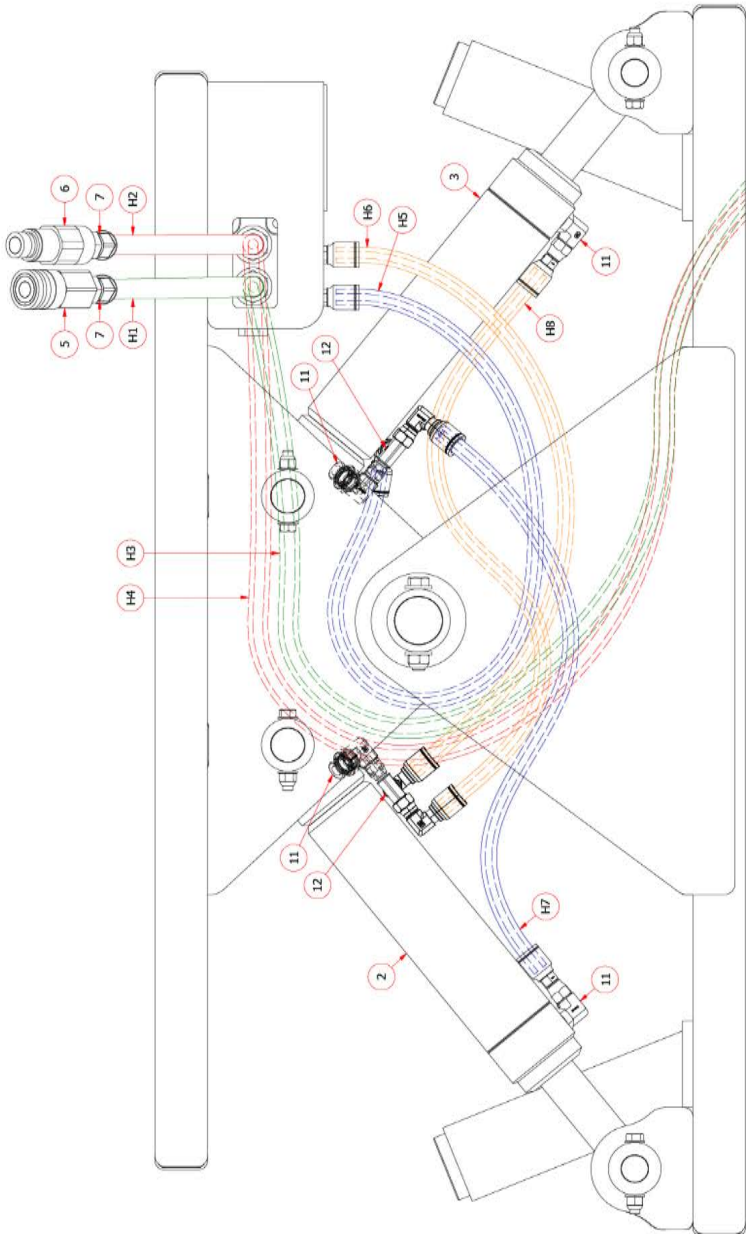

Diagram 3

THE PRODUCT IMAGES ARE FOR ILLUSTRATIVE PURPOSES ONLY AND MAY NOT BE AN EXACT REPRESENTATION OF THE PRODUCT. NORM ENG. RESERVES THE RIGHT TO CHANGE PRODUCT IMAGES AND SPECIFICATIONS AT ANY TIME WITHOUT NOTICE.

ANGLE BROOM



11 APPENDICES

11.1 SAFETY SIGN LOCATION

Item	Description
1	Warning Pinch point
2	Danger High pressure fluid
3	Warning Attachment can contact machine
4	Danger Read the Manual



ITEM 1



ITEM 2



ITEM 3



ITEM 4

Instructions

- Keep all safety signs clear and legible.
- Replace all missing, illegible, or damaged safety signs.
- When replacing parts which have safety signs attached make sure the replacement part has the safety sign.

12 WARRANTY

12.1 DEFINITION

“Dealer” means a dealer that purchases products directly from Norm Engineering Pty Ltd.

“End consumer” means a consumer that purchases products either directly from Norm Engineering Pty Ltd or directly from a “dealer” as defined above.

“Products” includes goods and services.

12.2 WARRANTY

Norm Engineering Pty Ltd welcomes you as a purchaser of its products. All Norm Engineering products are designed to ensure the highest standards, reliability, and performance.

Norm Engineering Pty Ltd warrants hydraulic cylinders against defects in manufacture for a period of twelve months from date of sale by the dealer or Norm Engineering Pty Ltd to the end consumer. The warranty in relation to hydraulic cylinders ceases upon the occurrence of damage to the piston rod of the hydraulic cylinder.

No warranty applies to hoses, tubes, and fittings in relation to any of the products.

Norm Engineering Pty Ltd warrants all its other products against defects in manufacture for a period of twelve months from the date of sale by the dealer or Norm Engineering Pty Ltd to the end consumer.

Norm Engineering Pty Ltd will, subject to the terms of this warranty, in relation to defective goods:

- a) replace the defective goods at no cost to the end consumer; or
- b) repair the defective goods at no cost to the end consumer; or
- c) pay the cost of having the defective goods repaired.

Norm Engineering Pty Ltd will, subject to the terms of this warranty, in relation to defective services:

- a) supply the services again to the end consumer at no cost to the end consumer; or
- b) pay the cost of having the service supplied again to the end consumer.

Warranty claims may be sent either to Norm Engineering Pty Ltd., P.O. Box 178, Mt Ommaney, Qld. 4074 or to the dealer.

All warranty periods shall commence from the date of sale by Norm Engineering Pty Ltd or the dealer to the end consumer. It is the end consumer's responsibility to establish the date of sale of the product to the end consumer by the dealer.

The end consumer may establish the date of sale by producing to Norm Engineering Pty Ltd the dated contract of sale between the end consumer and the dealer with its warranty claim.

If the end consumer is not able to establish the date of sale of the product to the end consumer by the date of its warranty claim, the warranty period shall be deemed to commence from the date of sale of the product by Norm Engineering Pty Ltd to the dealer.

This warranty will not apply if the end consumer does not use the product in accordance with Norm Engineering Pty Ltd's recommendation.

This warranty will not apply if the end consumer does not use products applied or fitted to any machine, equipment, or plant, in accordance with Norm Engineering Pty Ltd's operating recommendation for the product.

This warranty does not apply to any loss or damage caused through consequential neglect. Unless the end consumer indicates to Norm Engineering Pty Ltd prior to purchasing the product that it intends to use the product for a particular purpose, there is no implied warranty that the product will fit for that particular purpose. Ask Norm Engineering for clarification of the intended use is not included in the manual.

Only a dealer authorised in writing, or issued with an order number, by Norm Engineering Pty Ltd may carry out warranty repairs. Prior written approval must be obtained from Norm Engineering Pty Ltd before warranty repairs are carried out. Norm Engineering Pty Ltd will not recognise any warranty claim for reimbursement of repair costs unless the repairs have been carried out by an authorised dealer with prior written approval from Norm Engineering Pty Ltd to carry out the repairs.

Norm Engineering Pty Ltd limits its liability, as follows:

1) Pursuant to Section 68A of the Trade Practices Act 1974, this clause applies in respect of any of the goods or services supplied under this contract which are not of a kind ordinarily acquired for personal, domestic or household use or consumption, provided that this clause will not apply if the end consumer establishes that reliance on it would not be fair and reasonable.

2) Liability for breach of a condition or warranty implied into this contract by the Trade Practices Act 1974 other than a condition implied by Section 69 is limited:

a) In the case of goods, to any one of the following as determined by Norm Engineering Pty Ltd:

i. the replacement of goods

ii. the repair of the goods

iii. the payment of the cost of having the goods repaired, excluding travelling and freight charges.

b) In the case of services, to any one of the following as determined by Norm Engineering Pty Ltd.

i. the supplying of the services again; or

ii. the payment of the cost of having the services supplied again

Expenses incurred by the end consumer in connection with making a warranty claim shall be borne by the end consumer unless otherwise agreed by Norm Engineering Pty Ltd.

To the extent permitted by law, all implied conditions, and warranties in the contract of sale between Norm Engineering Pty Ltd and the end consumer are hereby excluded.

The benefits conferred by this warranty on the end consumer are in addition to all other legal rights and remedies that the end consumer has in respect of the products.

Contracts of sale for products, and this warranty are submitted to the exclusive jurisdiction of the courts of Queensland.

Notes:

Notes:



WARRANTY NOTICE

DEALER:

STATE: SIGNED:

END CONSUMER:

NAME:

ADDRESS:

.....

.....

STATE: POSTAL CODE:

PHONE: SIGNED:

DATE OF SALE TO THE END CONSUMER:/...../.....

DESCRIPTION OF PRODUCTS:

.....

.....

.....

SERIAL NO:

DELIVERY DOCKET NO:

DELIVERY DATE:/...../.....

NOTE: THIS FORM IS TO BE COMPLETED BY THE DEALER AND RETURNED TO: NORM ENGINEERING - P O BOX 178 MT OMMANEY, BRISBANE, QUEENSLAND, AUSTRALIA, 4074