

MOVING the earth for **you**™

NORM
ENGINEERING



Norm Engineering

TILTING HYDRAULIC QUICK HITCH

Manufacturer of
Earthmoving Attachments for:
Skid Steer Loaders
Backhoes
Excavators



07 3376 3177

7-10T TILTING HYDRAULIC QUICK HITCH OPERATING & MAINTENANCE MANUAL

Version 1.0b

sales@normeng.com.au

• www.normeng.com.au

MELBOURNE

Ph: 03 9775 1965
Fax: 03 9770 8054
3/90 Colemans Road
Carrum Downs VIC 3201

BRISBANE

Ph: 07 3376 3177
Fax: 07 3376 3201
21 Spine Street
Sumner Park QLD 4074

Table of Contents

1	INTRODUCTION.....	1
2	SAFETY DEFINITIONS: TERMS AND SYMBOLS.....	2
3	SAFETY INSTRUCTIONS.....	2
3.1	IMPORTANT POINTS.....	4
4	INSTALLATION INSTRUCTIONS.....	5
4.1	FITTING THE QUICK HITCH.....	5
4.2	CONNECTING THE HYDRAULICS.....	6
4.2.1	IMPORTANT CONSIDERATIONS.....	6
4.3	ADJUSTING THE HITCH TIMING.....	7
5	OPERATING INSTRUCTIONS.....	9
5.1	OPERATING PRESSURE AND FLOW RATE.....	9
5.2	PICKING UP AN ATTACHMENT.....	9
5.3	RELEASING AN ATTACHMENT.....	10
5.4	DIPPER ARM EXTENTION.....	11
6	SPECIFIED OPERATIONS.....	13
6.1	SAFE OPERATING LIMITS.....	13
6.2	LIFTING LUG.....	13
6.2.1	CORRECT USAGE.....	14
6.3	INTENDED USE.....	14
6.4	REASONABLY FORSEABLE MISUSE.....	15
7	MAINTENANCE AND CARE.....	16
7.1	PRIOR TO USE.....	16
7.2	WEEKLY.....	16
7.3	ROUTINE INSPECTION (EVERY 12 WEEKS).....	17
7.4	THIRD PARTY INSPECTIONS (EVERY 52 WEEKS).....	17
7.5	REPAIRS.....	18
7.5.1	RECOMMENDED TOOLS.....	18
7.5.2	HYDRAULICS.....	18
7.5.3	LIFTING LUG REPAIR.....	18
7.5.4	WELDING TO THE ACTUATOR.....	19
7.6	DISMANTLING THE TILT HITCH.....	19
7.7	ASSEMBLING THE TILT HITCH.....	21
8	PARTS.....	22
8.1.1	ORDERING PARTS.....	22
9	PARTS LIST.....	23
	APPENDICES.....	26
A.1	SAFETY SIGN LOCATIONS.....	26
A.2	MAINTENANCE SCHEDULE SAMPLE.....	27

1 INTRODUCTION



Congratulations on purchasing a Norm Engineering Pty Ltd attachment. We have designed this tilting quick hitch for a long, productive and safe life. Your tilt hitch will provide you with years of service provided regular maintenance and correct usage is applied.





This manual offers a guide on how to safely install, operate and maintain your tilting quick hitch. While the manual attempts to cover most situations, there are many unforeseen risks and events that are not included due to the capability of the tilting quick hitch. On this basis the owner and/or operator must determine if this tilt hitch is suited for a particular purpose.

Norm Engineering Pty Ltd can accept no responsibility or liability for how you operate your equipment: we can only provide warning notes and safety precautions in relation to the standard operation of the tilting quick hitch.

The illustrations and data used in this manual were current at the time of printing but due to possible engineering and/or production changes, this product may vary slightly. Norm Engineering Pty Ltd reserves the right to redesign and/or change components as may be necessary without notification.

2 SAFETY DEFINITIONS: TERMS AND SYMBOLS

We will use the ANSI Z535.4-2007 standard for the definitions of signal words as described in conjunction with colours red, orange and yellow. These are used with the Safety Alert Symbol:

- **Signal word:** The word that calls attention to the safety sign and designates a degree or level of hazard seriousness. The signal words for product safety signs are "DANGER", "WARNING", "CAUTION", and "NOTICE".
- **DANGER:** Indicates a hazardous situation, which, if not avoided, **will** result in death or serious injury. This signal word is to be limited to the most extreme situations. (White letters on a red background)

- **WARNING:** Indicates a hazardous situation, which, if not avoided, **could** result in death or serious injury. (Black letters on an orange background)

- **CAUTION:** Indicates a hazardous situation, which, if not avoided, **could** result in minor or moderate injury. It may also be used without the safety alert symbol as an alternative to "Notice". (Black letters on a yellow background)

- **NOTICE:** "NOTICE" is the preferred signal word to address practices not related to personal injury. The safety alert symbol shall not be used with this signal word.

- **CAUTION:** As an alternative to "NOTICE" the word "CAUTION" without the safety alert symbol may be used to indicate a message not related to personal injury.

3 SAFETY INSTRUCTIONS



Obey all the safety instructions listed in this section and throughout this manual. Failure to follow instructions could result in death or serious injury.



Before attempting any type of assembly operation, maintenance, or other work on or near this product:

- READ and COMPLETELY UNDERSTAND:
 - This manual,
 - The manuals provided with the power unit being used with this tilting quick hitch.
- Read and understand all safety signs associated with the equipment being used.
- Know all your controls and know how to quickly stop all power unit movement and the engine in case of an emergency.

SAFETY IS YOUR RESPONSIBILITY AS THE OPERATOR OF THE EQUIPMENT

Inappropriate and/or irresponsible use of a tilt hitch may cause serious injury and trauma. The operator must have all relevant industry competencies, qualifications, certificates and/or licenses.

The operator must understand their responsibilities under the relevant acts and regulations of the governing body. Failure to comply with your legal obligations under the act may result in prosecutions against you.

As the equipment operator you are responsible to familiarise yourself, and anyone else who will assemble, operate, maintain, or work around this product with the safety information contained within this manual. You must make certain that all operators and maintenance personnel have a complete understanding of the full and exact contents of this manual and those of the power unit.

There are usually specific precautions and steps in the power unit operating manual to be taken to ensure your safety prior to engaging the tilting quick hitch.

Conduct a job site survey during the planning phase of any construction project to identify potential hazards and develop and implement appropriate control measures to protect workers.

Accidents are preventable if the equipment operator is careful and responsible. No accident prevention program can be successful unless there is a wholehearted commitment and cooperation of the person who is directly responsible for the operation of the equipment.

Make sure anyone who will be installing, maintaining, repairing, removing, and/or storing this product applies the Workplace Health and Safety Act requirements. This includes ensuring that the person has been instructed in the safe operation of this product and of the power unit to which this tilt hitch is likely to be attached.

Know and follow good work practices, some of these include:

- Work on a level surface in a well-lit area.
- Keep the area clean and dry.
- Use properly grounded electrical outlets & tools.
- Use the right tool for the job at hand.
- Make sure that your tools are in good condition for performing the required function.
- When using tools, wear the protective equipment specified by the tool manufacturer (i.e. hardhat, safety glasses, work gloves, protective shoes, etc.)
- When the tilt hitch has been out in the sun, remember to wear protective gloves as the metal will be hot to touch.

3.1 IMPORTANT POINTS

When your power unit is used during any type of assembly, operation, maintenance or other work on or near this product:

- Before leaving the operator's station or before beginning any type of work on this product, lower this product to the ground, apply your power unit's parking brake, stop the engine, remove the starter key, wait for all moving parts to stop and then relieve all pressure in the hydraulic lines. Refer to your power unit's operating manual for instructions on preparing the equipment for hitching up an attachment and relieving hydraulic pressure in lines.
- Know your power unit's safe lifting and operating capacity and the weight of this product. (Check operator manuals for safe operating limits).
- Only allow the operator to be around the power unit or this product when either is in motion. Ensure work area is clear of all personnel.
- Apply all safety guidelines in relation to the operator and the equipment.
- Only operate controls from the operator's station.
- Maintain operator presence at all times when the engine is running or the product is raised on the power unit.
- Reduce speeds when additional weight and width need to be considered especially over rough ground.
- Whilst in motion keep the product close to the ground and under control.

4 INSTALLATION INSTRUCTIONS

⚠ WARNING

Obey all instructions listed in this section of the manual. Failure to follow the instructions listed below could lead to serious injuries.

Before commencing any installation work, ensure any persons working on or around this attachment have read and completely understood the contents of this manual. Only competent and experienced personnel should be involved during the installation process.

The installation of hydraulics should be carried out by a certified and qualified hydraulics fitter. **Before** making any modifications to the parent machine, please contact the manufacturer or dealer.

For any assistance with the installation process, please contact Norm Engineering Pty Ltd.

4.1 FITTING THE QUICK HITCH

Step 1: Before beginning any work on this product, lower the attachment onto the ground on a firm level surface that is large enough to safely accommodate the product, the power unit and all workers involved in installing this hitch.

Step 2: Position the O-Rings on the hitch bushes in the grooves provided.

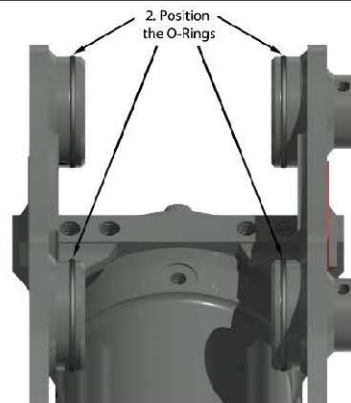

Step 3:

- a. Adjust the dipper arm position until the bore aligns neatly with the hitch bushes closest to the machine.
- b. Ensure the pin and bushes have been cleaned and greased before inserting the pin.

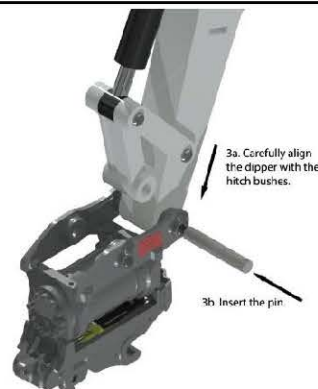

Step 4:

- a. Adjust the H-link position until the bore aligns neatly with the remaining hitch bushes.
- b. Ensure the pin and bushes have been cleaned and greased before inserting the pin.

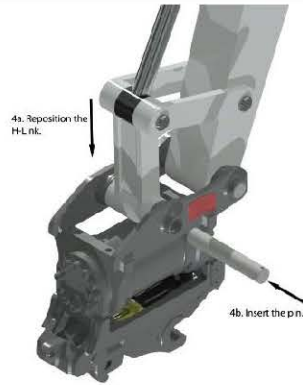

Step 5:

- a. Retain the pins. Note the method for securing the pins may vary, depending on the parent machine.
- b. Roll the O-Rings into place, creating a seal against environmental contaminants.



4.2 CONNECTING THE HYDRAULICS

WARNING

Read and understand all safety requirements prior to beginning the configuration of the hydraulics. Installation of the hydraulics must be conducted by a fully certified and qualified hydraulics fitter.

Connect the locking cylinder to the hydraulic locking circuit on the parent machine using 1/4" or 3/16" hydraulic hose. Note, the parent machine may not come standard with a hydraulic locking circuit. If this is the case, a qualified hydraulics fitter will need to install the circuit. The fittings on the locking cylinder are 7/16 JIC M.

The tilt actuator has ten M18x1.5 ports. Two connection ports (P1 and P2) and eight vent ports. Any of the vent ports can be used as alternate connection ports if required. Norm Engineering Pty Ltd recommends using only the vent ports that point up when the tilt hitch is in its normal upright position.

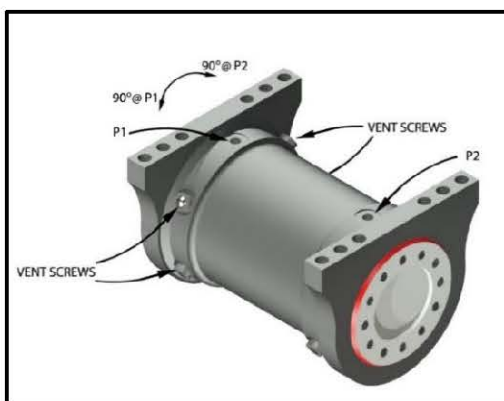

For advice on routing the hoses from the hitch, please contact Norm Engineering Pty Ltd.

4.2.1 IMPORTANT CONSIDERATIONS

1. The hydraulic hose should be either spiral wrapped or covered by a sleeve to guard against wear.
2. When determining the length of the hydraulic hose, ensure the hitch is positioned at full curl.
3. After installing the hydraulic hose, it is important to rotate the hitch through its full range of motion. Carefully examine the hoses during this process to make sure they do not get pinched or over extended.

4.3 ADJUSTING THE HITCH TIMING

NOTICE

The timing of every hitch is set and verified by Norm Engineering Pty Ltd before delivery.

NOTICE

This step is crucial to the safe operation of your hydraulic quick hitch. It is imperative that these steps are performed after repairs are performed on the hitch.

⚠ WARNING

The timing of the hydraulic quick hitch is the responsibility of the **operator**. Incorrect timing may lead to the unsafe release of an attachment. Make no assumptions about the operation of the quick hitch. Ensure the timing is set in accordance to the following directions.

The timing of the locking/unlocking mechanism is controlled by the position of two components:

1. The lifting ring
2. The front lock nuts

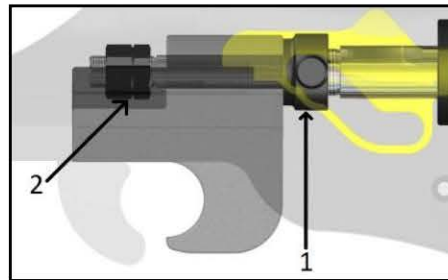

Step 1:

Check the initial position of the lifting ring. This should be situated approximately 140mm from the end of the rod.

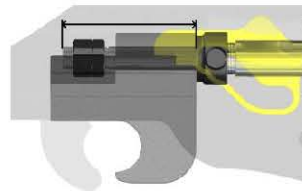

Step 2:

Adjust the front nuts until there is enough clearance for the secondary locking arm to clear the jaw during the unlocking cycle. This is typically 44mm from the end of the rod.

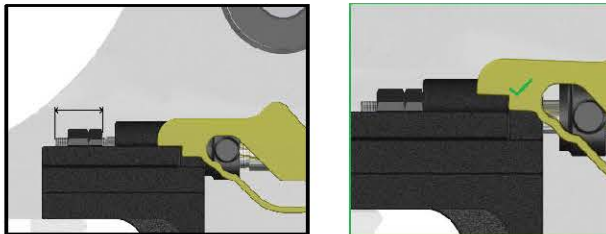

Step 3:

Verify that with the cylinder fully retracted, the rear of the locking arm is releasing the rear pin.

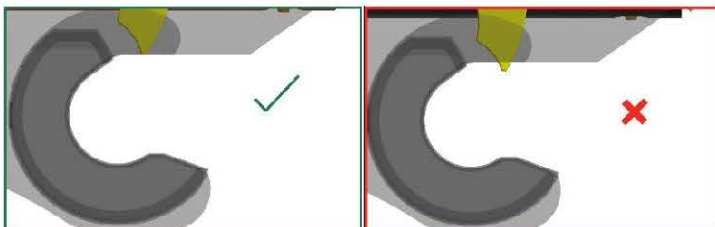

If the rear lock is not clearing the back pin, the lifting ring will need further adjustment. While holding the lifting ring, turn the rod clockwise to move the ring further along the thread.

Repeat Step 2 to ensure the front of the secondary lock clears the jaw during the unlocking process.

Step 4:

Secure the lifting ring using a **new** M8 grub screw. Do **not** reuse the old grub screw.

Tighten the two front nuts to lock them and prevent them from moving.

5 OPERATING INSTRUCTIONS

5.1 OPERATING PRESSURE AND FLOW RATE

⚠ DANGER Whilst in use, the locking circuit should always maintain pilot pressure (500 PSI).

The locking/unlocking circuit of this quick hitch has been designed to operate with as little as 500 PSI of pressure (pilot pressure), through to full machine pressure.

The tilting circuit should operate at a pressure between 2750PSI and 3000PSI for optimal performance. Operating at a lower pressure will reduce the torque produced by the tilting actuator.

The flow rate of the tilting circuit directly affects the swing time of the hitch. The table below gives the expected time to rotate 180 degrees at various flow rates.

Tilt Circuit Flow Rate (litres/minute)	Swing Time (seconds)
20	6.2
30	4.1
40	3.1
50	2.5
60	2.1
70	1.8

5.2 PICKING UP AN ATTACHMENT

⚠ WARNING Before commencing the following procedure, move the machine away from other personnel and onto a firm level surface that is large enough to safely accommodate the machine, the attachment and all workers involved in the process.

The pickup technique varies slightly to hitches that are not fitted with anti-swing. Once familiar with the technique, picking up an attachment will feel natural.

Step 1: Ensure the locking jaw has been fully retracted.



Step 2: Engage the pin closest to the cab.



Step 3:

- a) Slide the hitch slightly away from your machine. This is to ensure the anti-swing mechanism clears the back pin.
- b) Curl the hitch around until the anti-swing clears the back pin.
- c) Continue to curl the hitch until the attachment's front pin slides back into the fixed jaw.

Please note, if the attachment's front pin is not firmly against the fixed jaw, the locking mechanism may fail to engage.

If this occurs please disengage the hitch, clean the fixed jaw and start the hitching up process again.

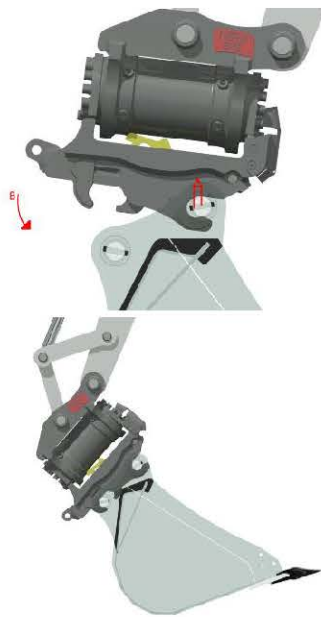

Step 4: Apply hydraulic pressure to lock the hitch.

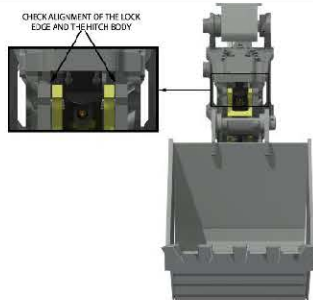
Step 5: From the cab, check the visual indicator to ensure the secondary locking mechanism has engaged. If the secondary lock has not engaged, DO NOT begin working. Disengage the lock and repeat Step 4.

Step 6: Before using your attachment:

- a. Press the attachment firmly against the ground.
- b. Give the attachment a couple of short, sharp movements close to the ground.

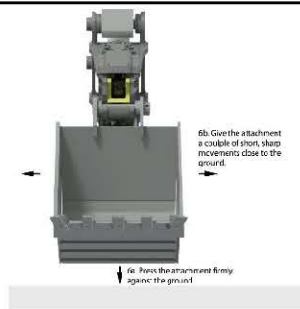

5.3 RELEASING AN ATTACHMENT



Before commencing the following procedure, move the machine from anywhere near other personnel and onto a firm level surface that is large enough to safely accommodate the machine, the attachment and all workers involved in the process.

Step 1: Lower the bucket/attachment to ground level.



Step 2: Apply hydraulic pressure to release the lock jaw. Ensure the jaw is fully retracted.



Step 3: Curl the hitch away from the cab until the rear pin is released.



Step 4: Swing the dipper arm to release the front pin. Store your attachment in a safe place, out of the elements.



5.4 DIPPER ARM EXTENTION



WARNING

Installing a tilting quick hitch extends the length of the dipper arm. In some situations it will be possible for the attachment to make contact with the cab and/or boom.

Ensure all personnel operating the power unit are aware of this danger and operate accordingly.

To ensure all operators are aware of this danger, Norm Engineering has provided a warning sticker with the hitch. If placed in the cab, all operators of the machine will be reminded of the danger.



Warning Sticker

6 SPECIFIED OPERATIONS

⚠ DANGER

This quick hitch has been designed for use on a standard bucket, in the traditional direction. Do not pick up any attachment in the reverse direction.

Correct Orientation

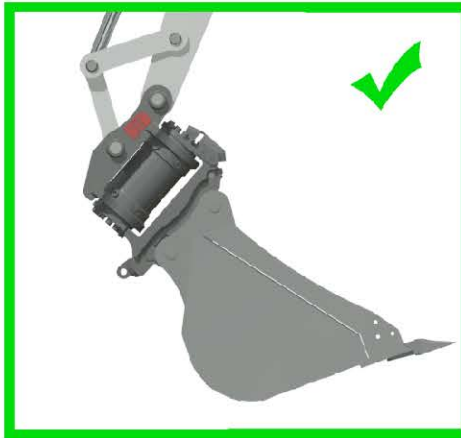

Incorrect Orientation



6.1 SAFE OPERATING LIMITS

⚠ WARNING

Refer to the parent equipment manual to ensure you follow all the limits specified. Do not exceed load limits.

Ensure that when determining your safe operating limits, the weight of the quick hitch is taken into account. The hitch weight is located on the data tag.

NOTICE

The maximum bucket width that can be safely used with the tilt hitch is 1500mm. If using an attachment wider than 1500mm, consult Norm Engineering Pty Ltd before commencing any work.

6.2 LIFTING LUG

The safe working load (SWL) for the quick hitch's lifting point can be found on the data tag fixed on the machine.



⚠ DANGER

It is imperative that you consult your power unit's safe lifting rating and always use the smaller of the lifting capacities.

6.2.1 CORRECT USAGE

⚠ WARNING

Incorrect use of the lifting lug may lead to serious injury or even fatality. Obey all instructions listed below.

- **Only** use the lifting point with the hitch crowded past horizontal, towards the machine. As illustrated in the picture below.
- **Only** use certified lifting lug on the hitch. **Do not** use any other part of the hitch as a lifting point.
- **Do not** exceed the SWL of the parent machine or the lifting capacity stated on the hitch data plate.
- **Do not** attempt to use the anti-swing as a lifting device.
- **Do not** attempt to use the fixed jaw as a lifting device.

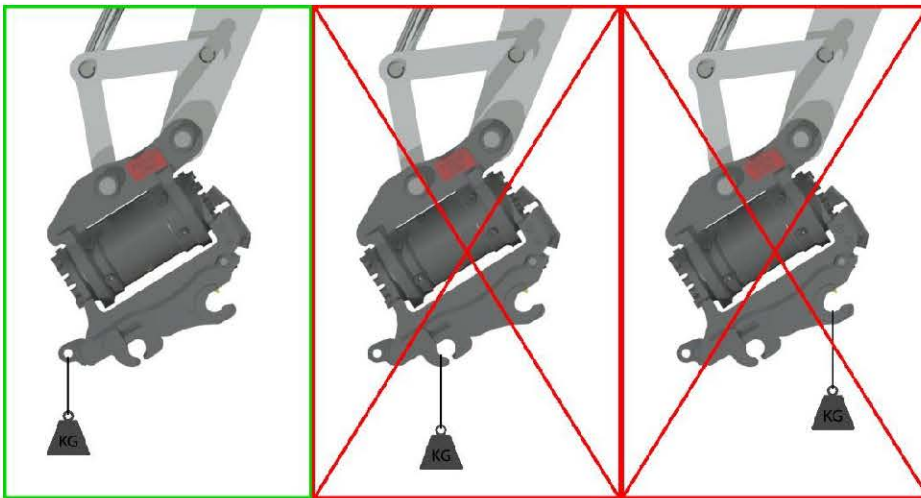

Correct use.

Do not use the anti-swing as a lifting point.

Do not use the fixed jaw as a lifting point.

6.3 INTENDED USE

- The tilt hitch is to be exclusively used for coupling and positioning attachments and buckets.
- The actuator angle must be set before beginning excavation.
- When digging, ensure the equipment being used is wider than the hitch to avoid damaging hoses and connections.
- The tilt hitch is intended for use within the following temperature range:
 - -18°C to 70°C

6.4 REASONABLY FORSEABLE MISUSE

Misuse of the tilting hitch will invalidate the warranty offered by Norm Engineering. Cost of repairs will be the sole responsibility of the operating company.

Reasonably foreseeable misuses include but are not limited to:

- Using the tilt hitch to transport persons in/on attached equipment.
- Using the tilt hitch in explosive areas is forbidden.
- Using the tilt hitch in contaminated areas is forbidden.
- Using the tilt hitch in extreme temperatures – see intended use for acceptable temperature range.
- Using the tilt hitch to tear down walls with the attached equipment.
- Spraying the tilt hitch with high-pressure cleaners or fire extinguishing equipment.
- Non-observed maintenance intervals.
- Neglected maintenance work.
- Incorrectly performed maintenance work.
- Using the hitch as a hammer or knocking device.
- Using the tilt hitch's fixed jaw as a load hook.
- Using the tilt hitch's fixed jaw and/or anti-swing for pushing, pulling or impact work.

7 MAINTENANCE AND CARE

NOTICE

After any maintenance and/or repairs is performed on the quick hitch, the timing of the hitch may require adjustment. Refer to *Section 4.3 Adjusting the Hitch Timing*.

NOTICE

When cleaning the tilt hitch, the following must be observed:

- Do not use any high-pressure cleaners or steam jets.
- High pressure cleaners could press dirt into the rotary actuator and cause damage.

7.1 PRIOR TO USE

Prior to use, the hitch shall be visually inspected to verify it is in an operational state. The inspection will check for:

- Signs of damage around the lifting lug, including: nicks; gouging; stretching; or distortion.
- Signs of wear, including corrosion and abrasive wear.
- Markings are legible.
- Welds are not damaged, cracked or worn.
- Hydraulic hoses, fittings, cylinders and actuators are in good conditions with no leaks.
- All fasteners are in place and correctly torqued.
- Signs of wear to the springs, ensuring they are firmly in place and there is no visual overstretching.
- Ensure the fixed jaw is not damaged and clear of any material build-up:

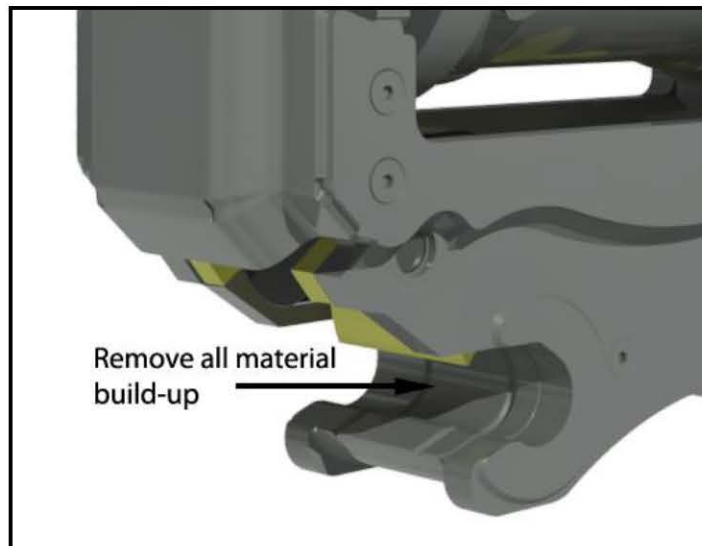

7.2 WEEKLY

⚠ DANGER

Before beginning any work on or around the hitch, it is imperative that the machine is turned off and the hydraulic pressure has been released.

On a weekly basis, the secondary locking arm track must be greased – both the top and bottom of the tracks as highlighted in yellow below.

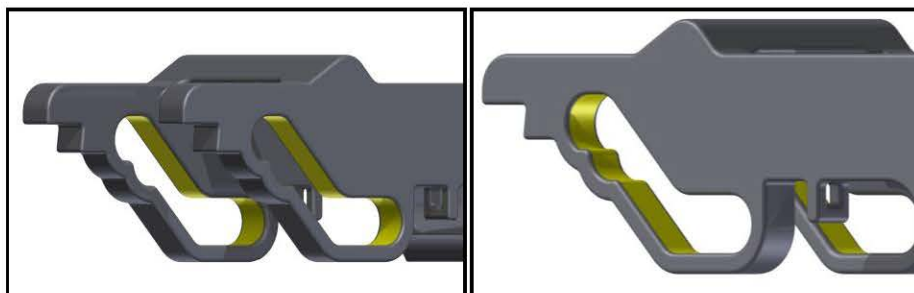

NOTICE

This is a critical step in the maintenance of your hitch. Premature wear or damage will not be covered under warranty.

7.3 ROUTINE INSPECTION (EVERY 12 WEEKS)

In accordance to *AS2550.1*, any lifting device must undergo a routine inspection every 12 weeks. Inspections must be performed in accordance to *AS4991 (Clause 15.1.3)*.

Routine inspections should include but are not limited to the following:

- Signs of abrasive wear, particularly around the pickup bushes and the lifting lugs. The critical wear zones for the quick hitch have been fabricated with wear indicators (See the figures below). Once the indicator is no longer visible, the hitch should be removed from service immediately and scheduled for repair.
- Signs of overloading such as stretching or distortion.
- Signs of damage in the load bearing sections of the lug: including nicks, cracks and gouging.
- Bolted connections, ensuring connections remain rigid and there are no signs of excessive stress.
- Excessive corrosion or heat damage.
- Marking legibility.
- Check the timing of the hitch. See Section 4.3 for instructions.

If the hitch fails to pass any of the above inspection criteria, it is to be clearly marked to indicate failure and removed from service. Contact the manufacturer for advice on repairing your hitch.



LIFTING LUG WEAR INDICATOR (HIGHLIGHTED IN RED)

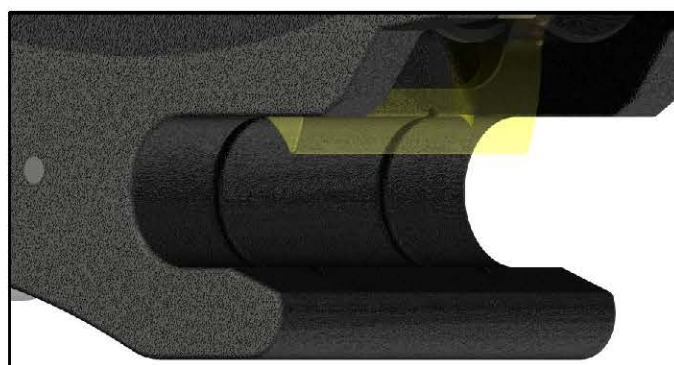

FRONT BUSH WEAR INDICATORS

In accordance to the Australian standards, an inspection record should be kept for each lifting device on this attachment.

7.4 THIRD PARTY INSPECTIONS (EVERY 52 WEEKS)

The lifting lug and locking jaw shall undergo third-party inspections every 52 weeks to ensure maintenance and repairs are in accordance to *AS2550.1*.

Non-destructive crack testing is recommended to detect any faults that may not be visible to the naked eye. This should be performed on the entire lifting lug by a NDT technician.

7.5 REPAIRS

NOTICE

All repair work must have prior approval from Norm Engineering Pty Ltd and be conducted by a qualified tradesperson.

WARNING

Before beginning any repair or maintenance on the actuator, Norm Engineering Pty Ltd recommends removing the tilt hitch from the power unit.

7.5.1 RECOMMENDED TOOLS

In order to perform maintenance work on the tilting hitch, the following tools and accessories are recommended:

- Seal Lifter
- Slide Hammer
- Torque Wrench
- Hexagon Socket Wrench Kit
- Grease Gun
- Plastic Hammer
- Medium Thread Locking Compound

7.5.2 HYDRAULICS

WARNING

Read and understand all safety requirements prior to beginning any maintenance to any hydraulic connections. It is imperative that if there are any fittings, repairs etc. required these must be conducted by a fully certified and qualified hydraulics fitter.

7.5.2.1 TILT ACTUATOR – WIPER SEAL REPLACEMENT

The rotary actuator used in this tilt hitch has been designed to be maintenance-free. However, it is recommended that the wiper rings are replaced every 1800 operating hours to increase the service life of the actuator.

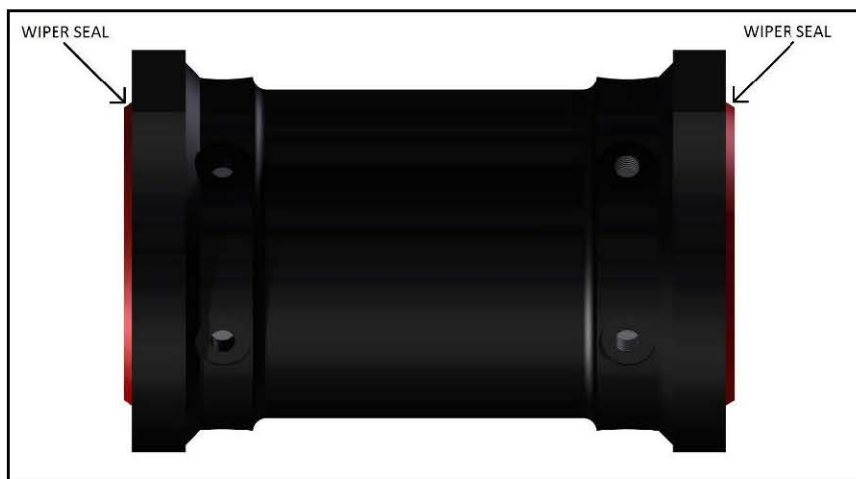

For instructions on dismantling the tilting hitch, please see Section 7.6. Once the actuator has been removed from the bottom half of the tilt hitch, complete the following steps:

1. Using a seal lifter, remove the wiper seal from the sealing groove.
2. Clean the sealing groove.
3. Completely grease the entire sealing groove and the seal with acid-free grease.
4. Push the new seal into the sealing groove. Repeat this process for a second wiper seal.

7.5.3 LIFTING LUG REPAIR

Minor damage such as nicks and gouges can be repaired by grinding and filing, so long as the thickness of the section is not reduced by more than 10% of its nominal dimension. Any repair that requires more than 10% of the original material to be removed must be reviewed by the manufacturer or a competent technician.

After repair work has been performed on the lifting lug, it should be tested against a proof load in accordance to AS4991. A proof load of two times the rated capacity of the lifting point should be applied. The rated capacity of the lifting point is as per the data plate on the hitch.

7.5.4 WELDING TO THE ACTUATOR

NOTICE

All welding must be performed by a qualified tradesperson. Welding to and/or around the actuator may cause damage – as such, it is imperative that any persons performing this task has read and fully understood the following instructions.

NOTICE

Before beginning any welding to the actuator, consult with Norm Engineering. Any unauthorised welding to the actuator will void the warranty.

7.5.4.1 WELDING PREPARATION

1. Using a seal lifter, remove the wiper seal from the sealing groove.
2. The rotary actuator must be masked around the area where the seal has been removed to prevent the seals from being damaged by weld beads. Heat-resistant tape must be used.
3. The nitrocarburate oxidate layer in the area around the weld seam down to a depth of at least 0.3mm.

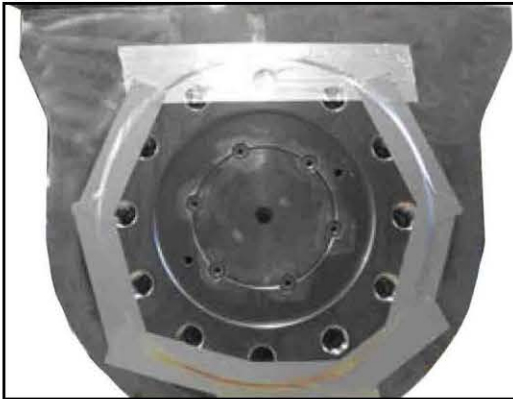

Welding Preparation

7.5.4.2 WELDING TEMPERATURE RANGE

During the welding operation, a temperature of 80°C **must** not be exceeded at the seals. An infrared thermometer should be used to check the temperature and welding should be paused if the temperature exceeds 80°C.

7.6 DISMANTLING THE TILT HITCH

⚠ DANGER

Dropping the tilt hitch or tilt hitch components may cause injuries or even be fatal. Secure the rotary actuator with retaining straps and crane.

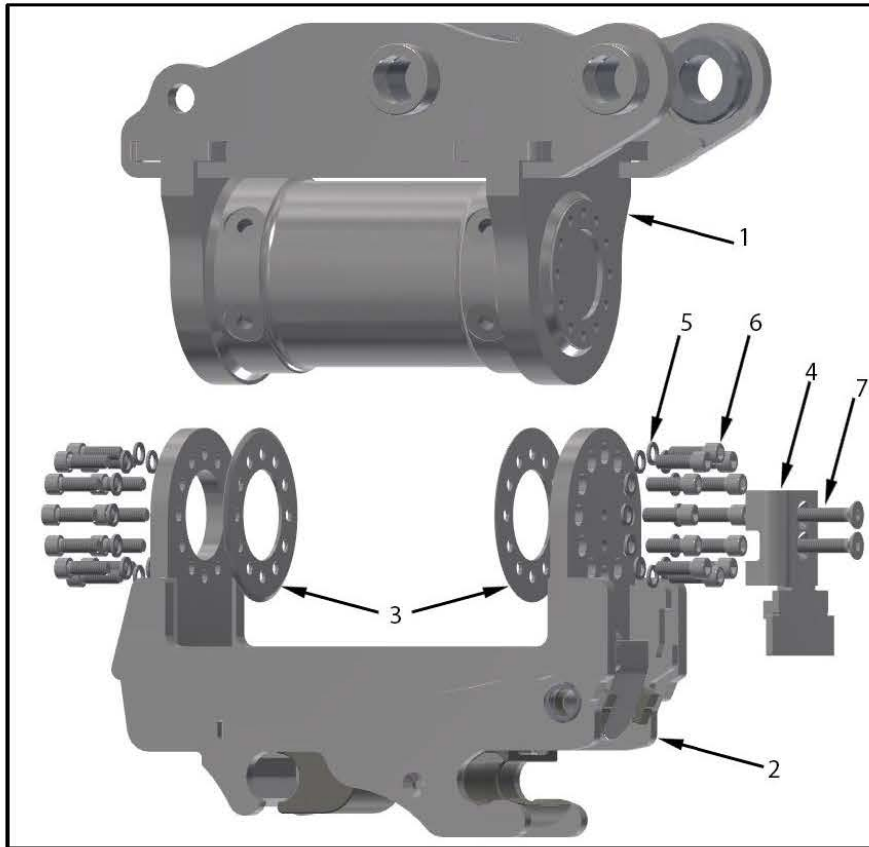

1. Using the crane, take the weight of the hitch.
2. Remove the two countersunk bolts (7) and the hose guard (4).
3. Release and undo all the fastening screws (5 and 6).
4. Pull the top half (1) out of the bottom half (2). Ensure the shims (3) are not lost in the process.

7.7 ASSEMBLING THE TILT HITCH

DANGER

Dropping the tilt hitch or tilt hitch components may cause injuries or even be fatal. Secure the rotary actuator with retaining straps and crane.

NOTICE

All the bolts used in assembling the tilting quick hitch require the use of anti-seize.

1. Using a crane, lower the top half (1) into the bottom half (2).
2. After ensuring the top half is stable, slide a shim (3) in-between the top and bottom halves. Loosely insert a socket head bolt and nord lock washer (5 and 6). This is to secure the first shim.
3. Repeat step 2 with the second shim. This shim may need to be tapped into place with a rubber mallet. Insert a second socket head bolt and washer.
4. Tighten the remaining bolts with nord lock washers (5 and 6) in a star pattern, only hand tight at first. Then tighten completely (in a star pattern) to 610Nm.
5. Reposition the hose guard (4) and secure with the countersunk bolts (7).

NOTICE

If any of the bolts require replacement, use only SAE Class 12.9.

8 PARTS

QUALITY BACKUP

*We make 90% of our parts... Ourselves.
This means we can get your parts to you... quickly.*

Refer to the exploded diagram included in this manual.

8.1 ORDERING PARTS

For ordering parts contact either your dealer or Norm Engineering directly. Contact details are included at the front of this manual. To assist, note the details of your hitch in the spaces provided under *Section 8.1.1 Reference Information*.

8.1.1 REFERENCE INFORMATION

Always refer to the model and serial number when ordering parts or requesting from you dealer. The serial number for this product is located on the identification place of your hitch.

Model Number:

Make:

Serial Number:

Date Purchased:

9 PARTS LIST

When ordering replacement parts, please include the following information:

- The machine make and model
- The serial number on the bucket
- The item number, as indicated by the following figures and tables.

STANDARD PARTS LIST

Item	Quantity	Description	Refer to Diagram
1	1	Machine side weldment	1
2	1	Attachment side weldment	1
3	1	Shim	1
4	1	Hose guard	1
5	1	Pivot pin	1
6	2	Secondary locking spring	1
7	24	Socket head bolt	1
8	24	Nord-lock washer	1
9	2	Hose guard countersunk bolt	1
10	2	Spring mount countersunk bolt	1
11	2	Spring mount nyloc nut	1
12	2	Pivot pin internal circlip	1
13	1	Sliding jaw	2
14	1	Secondary locking arm	2
15	1	Locking collar	2
16	1	Hydraulic locking cylinder	2
17	1	Pilot operated check valve	2
18	1	Sliding jaw timing spring	2
19	1	Locking system nyloc nut	2
20	1	Locking system half nut	2
21	1	Locking collar grub screw	2

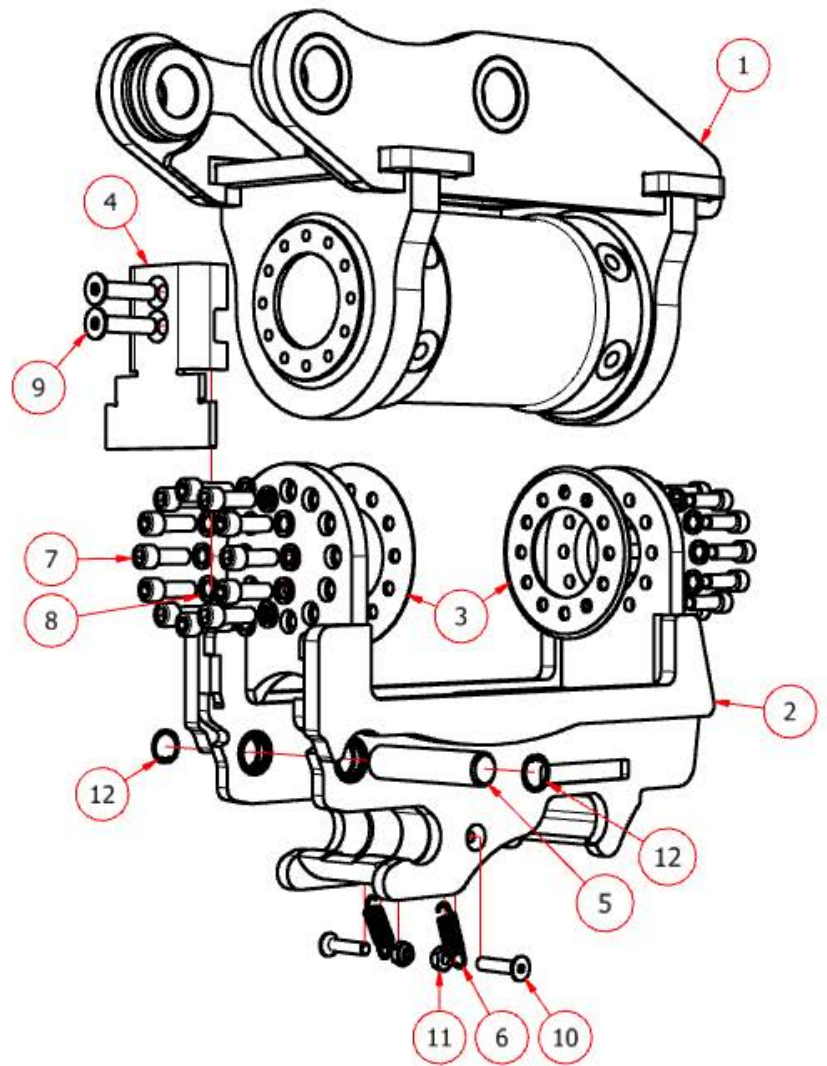
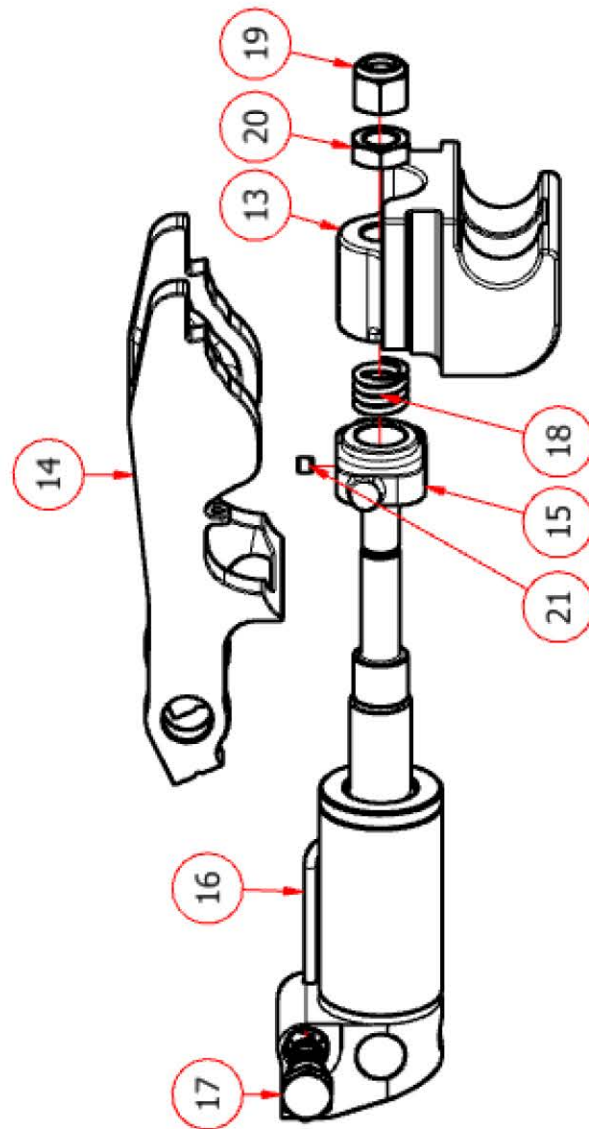

Diagram 2



APPENDICES

A.1 SAFETY SIGN LOCATIONS

Item	Description
1	Warning Pinching point
2	Warning This machine is fitted with an aftermarket hitch. Collision between the attachment and boom may be possible
3	Notice This automatic quick coupler complies with both AS 4772-2008 and ISO 13031.2. It DOES NOT require a safety pin.
4	Danger Read the manual



ITEM 1



ITEM 2



ITEM 3

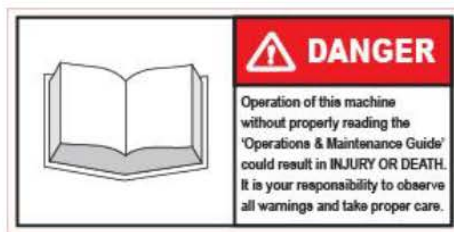

ITEM 4

Instructions

- Keep all safety signs clear and legible.
- Replace all missing, illegible, or damaged safety signs.
- When replacing parts which have safety signs attached make sure the replacement part has the safety sign.

A.2 MAINTENANCE SCHEDULE SAMPLE

Section 1 Prior to use checks <i>Recommended checks described in Section 7.1</i>				
Date	Time	Operator Safety Checks (name of operator or competent person)	Name of company	Signature
	am/pm			
	am/pm			
	am/pm			
	am/pm			
	am/pm			
	am/pm			

Section 2 Weekly and routine maintenance and safety checks <i>Recommended checks described in Section 7.2 and 7.3</i>					
Date	Hourmeter	Name of inspector	Company	Qualifications	Signature
	h				
	h				
	h				
	h				
	h				
	h				

Section 3 Third party maintenance and safety checks <i>Recommended checks described in Section 7.4</i>					
Date	Hourmeter	Name of inspector	Company	Qualifications	Signature
	h				
	h				
	h				
	h				
	h				
	h				

