



4-6T HYDRAULIC HITCH

OPERATING & PARTS MANUAL



SALES@NORMENG.COM.AU • 07 3376 3177 • WWW.NORMENG.COM.AU

BRISBANE

PH: 07 3376 3177
FAX: 07 3376 3201
787 BOUNDARY ROAD
DARRA QLD 4076

MELBOURNE

PH: 03 9775 1965
FAX: 03 9786 9102
2/45 FRANKSTON GARDENS DRIVE
CARRUM DOWNS VIC 3201

Contents

1	Introduction	1
2	Safety Definitions: Terms and Symbols.....	2
3	Safety Instructions	3
3.1	Important Points	5
4	Installation Instructions	6
4.1	Fitting the Quick Hitch	6
4.2	Connecting the Hydraulics	8
4.2.1	Important Considerations	8
4.3	Adjusting the Hitch Timing	8
5	Operating Instructions	11
5.1	Operating Pressure	11
5.2	Picking Up an Attachment.....	11
5.3	Releasing an Attachment	13
5.4	Dipper Arm Extention	15
6	Specified Operations.....	16
6.1	Safe Operating Limits.....	16
6.2	Lifting Lug.....	16
6.2.1	Correct Usage	17
6.3	Intended Use	18
6.4	Reasonably Foreseeable Misuse.....	19
7	Maintenance and Care.....	20
7.1	Prior to Use	20
7.2	Weekly.....	21
7.3	Routine Inspection (Every 12 Weeks).....	22
7.4	Third Party Inspections (Every 52 Weeks).....	23
7.5	Repairs	24
7.5.1	Lifting Lug Repair	24
7.5.2	Hydraulics.....	24

8	Risk Assessment	25
9	Parts	31
9.1	Ordering Parts	31
9.1.1	Reference Information.....	31
10	Parts List	32
	Appendices.....	34
A.1	Safety Sign Locations	34
A.2	Maintenance Schedule	35
11	Warranty	37
11.1	Definition	37
11.2	Warranty.....	37

1 INTRODUCTION



4-6T Hydraulic Quick Hitch

Congratulations on purchasing a Norm Engineering Pty Ltd attachment. We have designed this quick hitch for a long, productive, and safe life. Your quick hitch will provide you with years of service provided regular maintenance and correct usage is applied.

This manual offers a guide on how to safely install, operate and maintain your quick hitch. While the manual attempts to cover most situations, there are many unforeseen risks and events that are not included due to the capability of the quick hitch. On this basis the owner and/or operator must determine if this quick hitch is suited for a particular purpose.

Norm Engineering Pty Ltd can accept no responsibility or liability for how you operate your equipment: we can only provide warning notes and safety precautions in relation to the standard operation of the quick hitch.

The illustrations and data used in this manual were current at the time of printing but due to possible engineering and/or production changes, this product may vary slightly. Norm Engineering Pty Ltd reserves the right to redesign and/or change components as may be necessary without notification.

2 SAFETY DEFINITIONS: TERMS AND SYMBOLS

We will use the ANSI Z535.4-2011(R2017) standard for the definitions of signal words as described in conjunction with colours red, orange, and yellow. These are used with the Safety Alert Symbol:

- **Signal word:** Are defined as the words used in the signal word panel. The signal words for hazard alerting signs are “DANGER”, “WARNING”, and “CAUTION”. Safety notice signs use the signal word “NOTICE”. Safety instruction signs use signal words that are specific to the situation.
- **DANGER:** Indicates a hazardous situation, which, if not avoided, **will** result in death or serious injury. This signal word is to be limited to the most extreme situations. (White letters on a red background) 
- **WARNING:** Indicates a hazardous situation, which, if not avoided, **could** result in death or serious injury. (Black letters on an orange background) 
- **CAUTION:** Indicates a hazardous situation, which, if not avoided, **could** result in minor or moderate injury. (Black letters on a yellow background) 
- **NOTICE:** Indicates information considered important, but **not** hazard-related (e.g., messages relating to property damage). (White letters on a blue background) 
- **SAFETY INSTRUCTIONS:** Indicates a type of safety sign, where specific **safety-related instructions** or **procedures** are described. More definitive signal words are encouraged, where practical (e.g., SAFE SHUTDOWN PROCEDURE, SAFE OPERATING PROCEDURE). (White letters on a green background) 

3 SAFETY INSTRUCTIONS



WARNING

Obey all the safety instructions listed in this section and throughout this manual. Failure to follow instructions could result in death or serious injury.

NOTICE

Before attempting any type of assembly operation, maintenance, or other work on or near this product:

- READ and COMPLETELY UNDERSTAND:
 - This manual,
 - The manuals provided with the power unit being used with this quick hitch.
- Read and understand all safety signs associated with the equipment being used.
- Know all your controls and know how to quickly stop all power unit movement and the engine in case of an emergency.

SAFETY IS YOUR RESPONSIBILITY AS THE OPERATOR OF THE EQUIPMENT

Inappropriate and/or irresponsible use of a quick hitch may cause serious injury and trauma. The operator must have all relevant industry competencies, qualifications, certificates and/or licenses.

The operator must understand their responsibilities under the relevant acts and regulations of the governing body. Failure to comply with your legal obligations under the act may result in prosecutions against you.

As the equipment operator you are responsible to familiarise yourself, and anyone else who will assemble, operate, maintain, or work around this product with the safety information contained within this manual. You must make certain that all operators and maintenance personnel have a complete understanding of the full and exact contents of this manual and those of the power unit.

There are usually specific precautions and steps in the power unit operating manual to be taken to ensure your safety prior to engaging the quick hitch.

Conduct a job site survey during the planning phase of any construction project to identify potential hazards and develop and implement appropriate control measures to protect workers.

Accidents are preventable if the equipment operator is careful and responsible. No accident prevention program can be successful unless there is a wholehearted commitment and cooperation of the person who is directly responsible for the operation of the equipment.

Make sure anyone who will be installing, maintaining, repairing, removing, and/or storing this product applies the Workplace Health and Safety Act requirements. This includes ensuring that the person has been instructed in the safe operation of this product and of the power unit to which this quick hitch is likely to be attached.

Know and follow good work practices, some of these include:

- To optimise the physical environment such as having a well-lit, level surface that is clean and dry to work on.
- Use properly grounded, test and tagged electrical outlets and tools.
- Use the right tool for the job at hand.
- Make sure that your tools are in good condition for performing the required function.
- When using tools, wear the protective equipment specified by the tool manufacturer (hardhat, safety glasses, work gloves, protective shoe...)
- When the attachment has been out in the sun, remember to wear protective gloves as the metal will be hot to touch.
- Before starting, know the job duration, job complexity, and best procedure.
- Ensure workers have the capacity to do the job.
- Check that all hazards have been identified and control measures implemented.
- Clear communication so everyone present knows what is happening.
- Clear emergency stop procedure so there is no confusion in an emergency.
- Ensure the use of tyre stoppers and securing framework to stop the plant and plant attachment moving during maintenance.

3.1 IMPORTANT POINTS

When your power unit is used during any type of assembly, operation, maintenance, or other work on or near this product:

- Before leaving the operator's station or before beginning any type of work on this product, lower this product to the ground, apply your power unit's parking brake, stop the engine, remove the starter key, wait for all moving parts to stop, and then relieve all pressure in the hydraulic lines. Refer to your power unit's operating manual for instructions on preparing the equipment for hitching up an attachment and relieving hydraulic pressure in lines.
- Know your power unit's safe lifting and operating capacity and the weight of this product. (Check operator manuals for safe operating limits).
- Only allow the operator to be around the power unit or this product when either is in motion. Ensure work area is clear of all personnel.
- Apply all safety guidelines in relation to the operator and the equipment.
- Only operate controls from the operator's station.
- Maintain operator presence at all times when the engine is running, or the product is raised on the power unit.
- Reduce speeds when additional weight and width need to be considered especially over rough ground.
- Whilst in motion keep the product close to the ground and under control.

4 INSTALLATION INSTRUCTIONS



WARNING

Obey all instructions listed in this section of the manual. Failure to follow the instructions listed below could lead to serious injuries.

Before commencing any installation work, ensure any persons working on or around this attachment has read and completely understood the contents of this manual. Only competent and experienced personnel should be involved during the installation process.

The installation of hydraulics should be carried out by a certified and qualified hydraulics fitter. **Before** making any modifications to the parent machine, please contact the manufacturer or dealer.

For any assistance with the installation process, please contact Norm Engineering.

4.1 FITTING THE QUICK HITCH

Step 1: Before beginning any work on this product, lower the attachment onto the ground on a firm level surface that is large enough to safely accommodate the product, the power unit and all workers involved in installing this hitch.

Step 2: Position the O-Rings on the hitch bushes in the grooves provided.

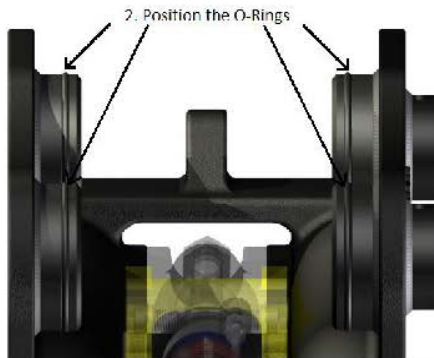

Step 3:

- a. Adjust the link arm position until the bore aligns neatly with the bushes located furthest from the front of the machine.
- b. Ensure the pin and bushes have been cleaned and greased before inserting the pin.

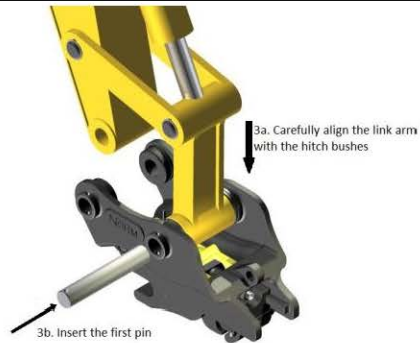

Step 4:

- a. Adjust the dipper arm position until the bore aligns neatly with the remaining hitch bushes.
- b. Ensure the pin and bushes have been cleaned and greased before inserting the pin.

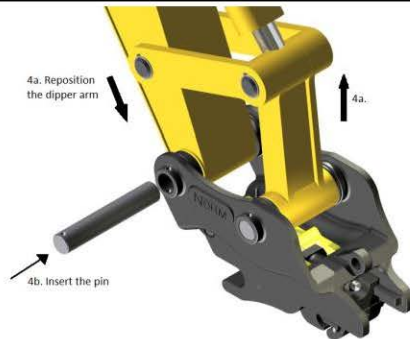

Step 5:

- a. Retain the pins. Note the method for securing the pins may vary, depending on the parent machine.
- b. Roll the O-Rings into place, creating a seal against environmental contaminants.

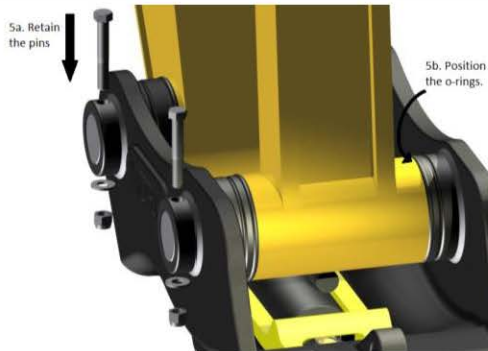

4.2 CONNECTING THE HYDRAULICS

WARNING

Read and understand all safety requirements prior to beginning the configuration of the hydraulics. Installation of the hydraulics must be conducted by a fully certified and qualified hydraulics fitter.

Connect the locking cylinder to the hydraulic locking circuit on the parent machine, using 1/4", 3/16" or DN4 hydraulic hose. Note, the parent machine may not come standard with a hydraulic locking circuit. If this is the case, a qualified hydraulics fitter will need to install the circuit.

The fittings on the hydraulic cylinder are 7/16 JIC M.

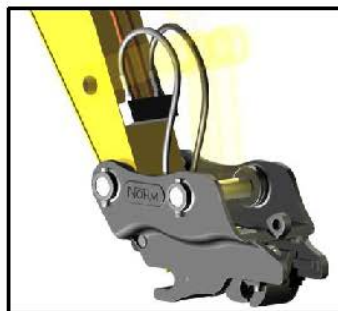

4.2.1 IMPORTANT CONSIDERATIONS

1. The hydraulic hose should be either spiral wrapped or covered by a sleeve to guard against wear.
2. When determining the length of the hydraulic hose, ensure the hitch is positioned at full curl.
3. After installing the hydraulic hose, it is important to rotate the hitch through its full range of motion. Carefully examine the hoses during this process to make sure they do not get pinched or over extended.

4.3 ADJUSTING THE HITCH TIMING

NOTICE

The timing of every hitch is set and verified by Norm Engineering Pty Ltd before delivery.

NOTICE

This step is crucial to the safe operation of your hydraulic quick hitch. It is imperative that these steps are performed after repairs are performed on the hitch.

⚠ WARNING

The timing of the hydraulic quick hitch is the responsibility of the **operator**. Incorrect timing may lead to the unsafe release of an attachment. Make no assumptions about the operation of the quick hitch. Ensure the timing is set in accordance with the following directions.

The timing of the locking and unlocking mechanism is controlled by the position of two components:

1. The lifting ring
2. The front lock nuts

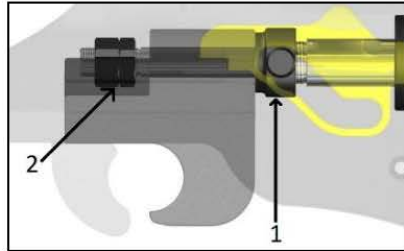

Step 1:

Check the initial position of the lifting ring. This should be situated approximately 120mm from the end of the rod.

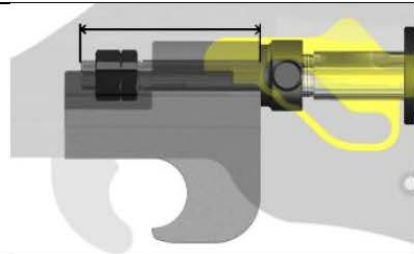

Step 2:

Adjust the front nuts until there is enough clearance for the secondary locking arm to clear the jaw during the unlocking cycle. This is typically 38mm from the end of the rod.

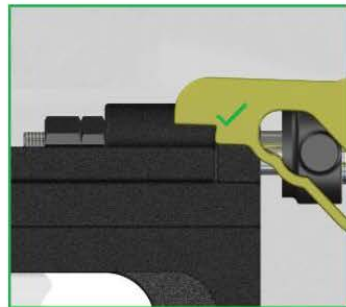
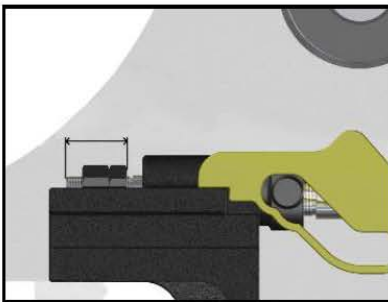

Step 3:

Verify that with the cylinder fully retracted, the rear of the locking arm is releasing the rear pin.

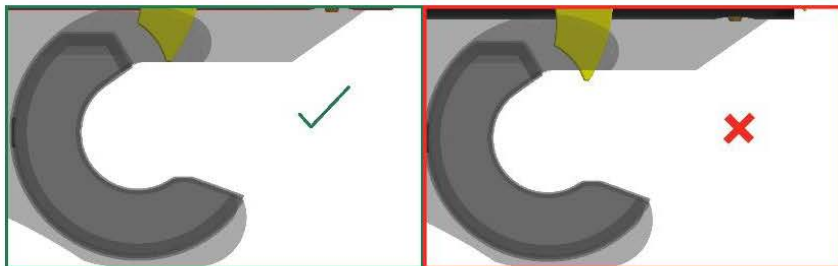

If the rear lock is not clearing the back pin, the lifting ring will need further adjustment. While holding the lifting ring, turn the rod clockwise to move the ring further along the thread.

Repeat Step 2 to ensure the front of the secondary lock clears the jaw during the unlocking process.

Step 4:

Secure the lifting ring using a **new** M8 grub screw. Do **not** reuse the old grub screw.

Tighten the two front nuts to lock them and prevent them from moving along the thread.

5 OPERATING INSTRUCTIONS

5.1 OPERATING PRESSURE



Whilst in use, the locking circuit should always maintain pilot pressure (500PSI).

The locking/unlocking circuit of this quick hitch has been designed to operate with as little as 500 PSI of pressure (pilot pressure), through to full system pressure.

5.2 PICKING UP AN ATTACHMENT



Before commencing the following procedure, move the machine from anywhere near other personnel and onto a firm level surface that is large enough to safely accommodate the machine, the attachment and all workers involved in the process.

The pickup technique varies slightly to hitches that are not fitted with anti-swing. Once familiar with the technique, picking up an attachment will feel natural.

Step 1: Ensure the locking jaw has been fully retracted.

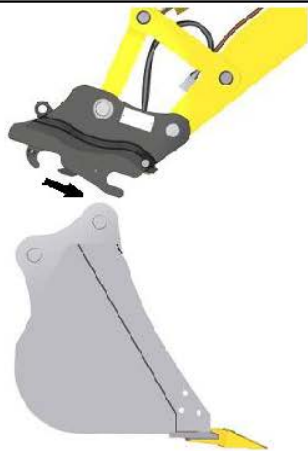

Step 2: Engage the pin closest to the cab.



Step 3:

- a) Slide the hitch slightly away from your machine. This is to ensure the anti-swing mechanism clears the back pin.
- b) Curl the hitch around until the anti-swing clears the back pin.
- c) Continue to curl the hitch until the attachments front pin slides back into the fixed jaw.

Please note, if the attachments front pin is not firmly against the fixed jaw, the locking mechanism may fail to engage.

If this occurs, please disengage the hitch, clean the fixed jaw, and start the hitching up process again.



Step 4: Apply hydraulic pressure to lock the hitch.



Step 5: From the cab, check the visual indicator to ensure the secondary locking mechanism has engaged. If the secondary lock has not engaged, DO NOT begin working. Disengage the lock and repeat Step 4.

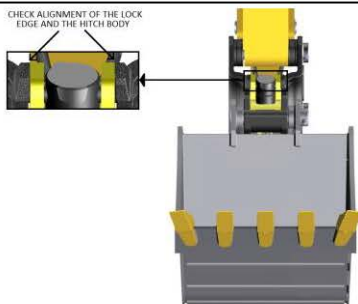

Step 6: Before using your attachment:

- Press the attachment firmly against the ground.
- Give the attachment a couple of short, sharp movements close to the ground.

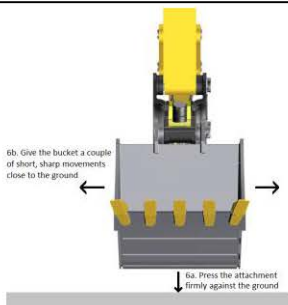

5.3 RELEASING AN ATTACHMENT

⚠ WARNING

Before commencing the following procedure, move the machine from anywhere near other personnel and onto a firm level surface that is large enough to safely accommodate the machine, the attachment and all workers involved in the process.

Step 1: Lower the bucket to ground level.

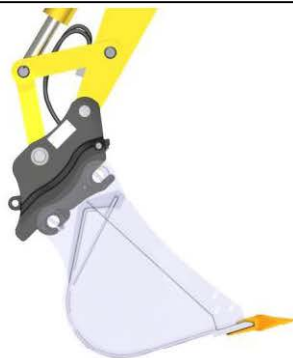

Step 2: Apply hydraulic pressure to release the lock jaw. Ensure the jaw is fully retracted.



Step 3: Curl the hitch away from the cab until the rear pin is released.



Step 4: Swing the dipper arm to release the front pin. Store your attachment in a safe place, out of the elements.

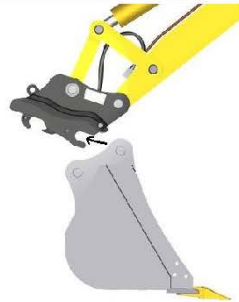

5.4 DIPPER ARM EXTENTION

⚠ WARNING

Installing a quick hitch extends the length of the dipper arm. In some situations, it will be possible for the attachment to contact the cab and/or boom. Ensure all personnel operating the power unit are aware of this danger and operate accordingly.

To ensure all operators are aware of this danger, Norm Engineering has provided a warning sticker with the hitch. If placed in the cab, all operators of the machine will be reminded of the danger.



Warning Sticker

6 SPECIFIED OPERATIONS

⚠ DANGER

This quick hitch has been designed for use on a standard bucket, in the traditional direction. Do not pick up any attachment in the reverse direction.

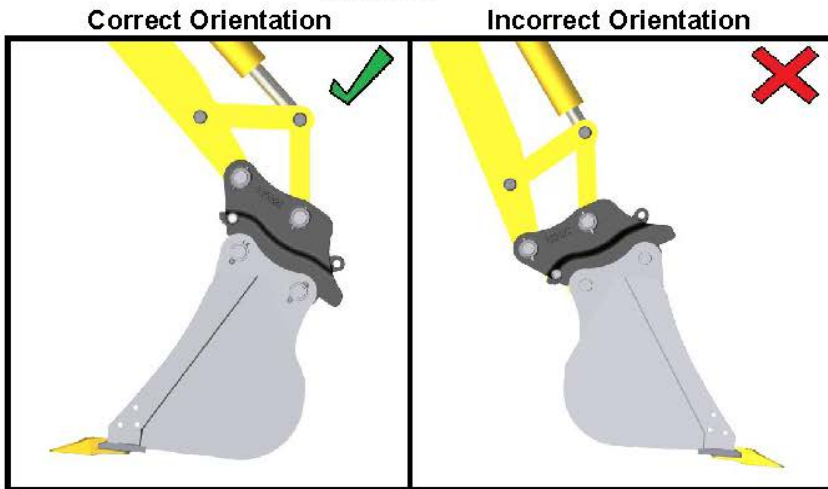

6.1 SAFE OPERATING LIMITS

⚠ WARNING

Refer to the parent equipment manual to ensure you follow all the limits specified. Do not exceed load limits.

Ensure that when determining your safe operating limits, the weight of the quick hitch is considered. The hitch weight is located on the data tag.

6.2 LIFTING LUG

The safe working load (SWL) for the quick hitch's lifting point can be found on the data tag fixed on the machine.



DANGER

It is imperative that you consult your power unit's safe lifting rating and always use the smaller of the lifting capacities.

6.2.1 CORRECT USAGE

WARNING

Incorrect use of the lifting lug may lead to serious injury or even fatality. Obey all instructions listed below.

- **Only** use the lifting point with the hitch crowded past horizontal, towards the machine. As illustrated in the picture below.
- **Only** use certified lifting lug on the hitch. **Do not** use any other part of the hitch as a lifting point.
- **Do not** exceed the SWL of the parent machine or the lifting capacity stated on the hitch data plate.
- **Do not** attempt to use the anti-swing as a lifting device.
- **Do not** attempt to use the fixed jaw as a lifting device.

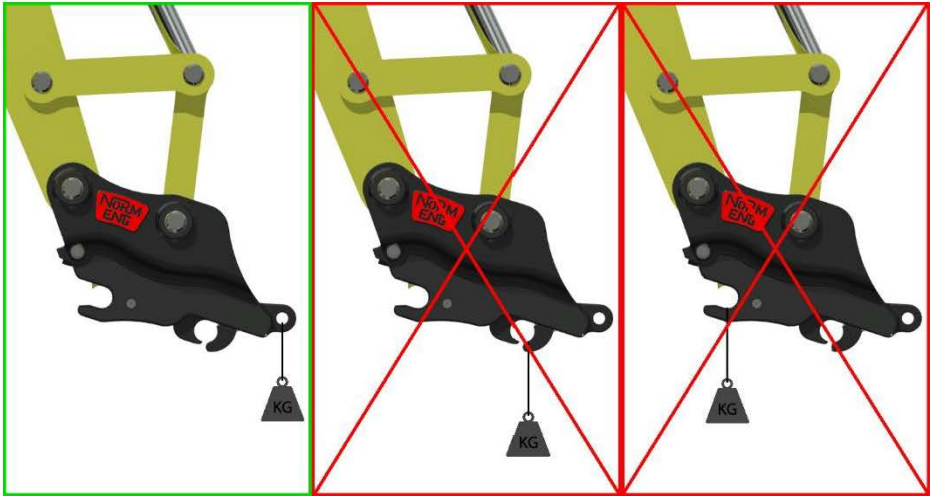

Correct use.

Do not use the anti-swing as a lifting point.

Do not use the fixed jaw as a lifting point.

6.3 INTENDED USE

- The hitch is to be exclusively used for coupling and positioning attachments and buckets.
- When digging, ensure the equipment being used is wider than the hitch to avoid damaging hoses and connections.
- Only the hitches rated lifting point should be used to carry any load – not any other part of the hitch.

6.4 REASONABLY FORSEABLE MISUSE

Misuse of the hitch will invalidate the warranty offered by Norm Engineering. Cost of repairs will be the sole responsibility of the operating company.

Reasonably foreseeable misuses include but are not limited to:

- Using the hitch to transport persons in/on attached equipment.
- Using the hitch in explosive areas is forbidden.
- Using the hitch in contaminated areas is forbidden.
- Spraying the hitch with high-pressure cleaners or fire extinguishing equipment.
- Non-observed maintenance intervals.
- Neglected maintenance work.
- Incorrectly performed maintenance work.
- Using the hitch as a hammer or knocking device.
- Using the hitch's fixed jaw as a load hook.
- Using the hitch's fixed jaw and/or anti-swing for pushing, pulling or impact work.

7 MAINTENANCE AND CARE

NOTICE

After any maintenance and/or repairs are performed on the quick hitch, the timing of the hitch may require adjustment. Refer to *Section*

4.3 Adjusting the Hitch Timing.

NOTICE

When cleaning the hitch, the following must be observed:

- Do not use any high-pressure cleaners or steam jets.
 - High pressure cleaners could press dirt into the seals of the hitch.

7.1 PRIOR TO USE

Prior to use, the hitch shall be visually inspected to verify the attachment is in an operational state. The inspection will check for:

- Signs of damage around the lifting lug, including nicks; gouging; stretching; or distortion.
- Signs of wear, including corrosion and abrasive wear.
- Markings are legible.
- Welds are not damaged, cracked or worn.
- Hydraulic hoses, fittings and cylinders are in good conditions with no leaks.
- All fasteners are in place and correctly torqued.
- Signs of wear to the springs, ensuring they are firmly in place and there is no visual overstretching.
- Ensure the fixed jaw is not damaged and clear of any material build-up:

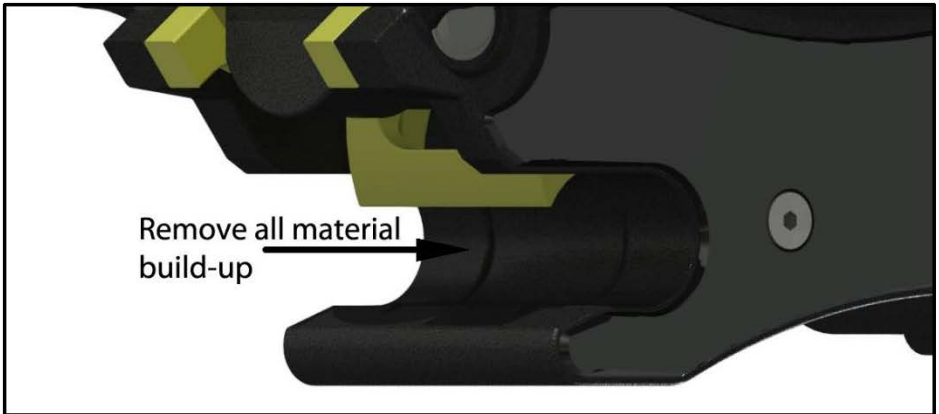

7.2 WEEKLY



Before beginning any work, it is imperative that the machine is turned off and the hydraulic pressure has been released.

On a weekly basis, the secondary locking arm track must be greased – both the top and bottom of the tracks as highlighted in yellow below.

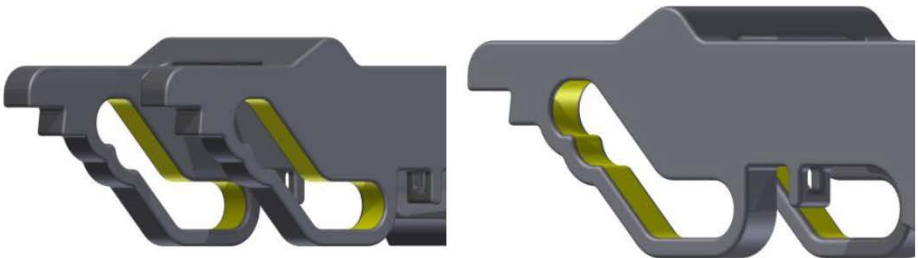

NOTICE

This is a critical step in the maintenance of your hitch. Premature wear or damage will not be covered under warranty. Refer to section 11 for further information.

7.3 ROUTINE INSPECTION (EVERY 12 WEEKS)

In accordance with *AS2550.1*, any lifting device must undergo a routine inspection every 12 weeks. Inspections must be performed in accordance with *AS4991 (Clause 15.1.3)*.

Routine inspections should include but are not limited to the following:

- Signs of abrasive wear, particularly around the pickup bushes and the lifting lugs. The critical wear zones for the quick hitch have been fabricated with wear indicators (See the figures below). Once the indicator is no longer visible, the hitch should be removed from service immediately and scheduled for repair.
- Signs of overloading such as stretching or distortion.
- Signs of damage in the load bearing sections of the lug: including nicks, cracks, and gouging.
- Bolted connections, ensuring connections remain rigid and there are no signs of excessive stress.
- Excessive corrosion or heat damage.
- Marking legibility.

If the hitch fails to pass any of the above inspection criteria, it is to be clearly marked to indicate failure and removed from service. Contact the manufacturer for advice on repairing your hitch.



LIFTING LUG WEAR INDICATOR (HIGHLIGHTED IN RED)

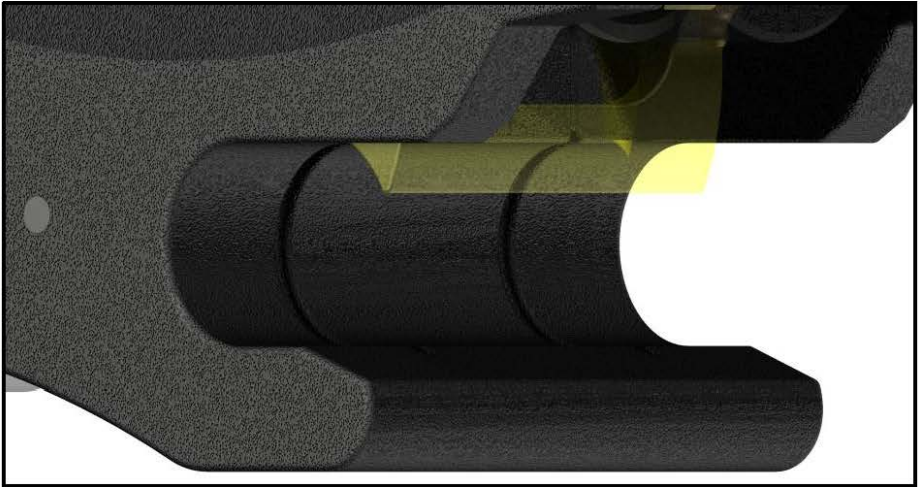

FRONT BUSH WEAR INDICATORS

In accordance with the Australian standards, an inspection record should be kept for each lifting device on this attachment.

7.4 THIRD PARTY INSPECTIONS (EVERY 52 WEEKS)

The lifting lug and locking jaw shall undergo third-party inspections every 52 weeks to ensure maintenance and repairs are in accordance with *AS2550.1*.

Non-destructive crack testing is recommended to detect any faults that may not be visible to the naked eye. This should be performed on the entire lifting lug by a NDT technician.

7.5 REPAIRS

NOTICE

All repair work must have prior approval from Norm Engineering Pty Ltd and be conducted by a qualified tradesperson.

WARNING

Before beginning any repair or maintenance on the actuator, Norm Engineering Pty Ltd recommends removing the hitch from the

power unit.

7.5.1 LIFTING LUG REPAIR

Minor damage such as nicks and gouges can be repaired by grinding and filing, so long as the thickness of the section is not reduced by more than 10% of its nominal dimension. Any repair that requires more than 10% of the original material to be removed must be reviewed by the manufacturer or a competent technician.

After repair work has been performed on the lifting lug, it should be tested against a proof load in accordance with *AS4991*. A proof load of two times the rated capacity of the lifting point should be applied. The rated capacity of the lifting point is as per the data plate on the hitch.

7.5.2 HYDRAULICS

WARNING

Read and understand all safety requirements prior to beginning any maintenance to any hydraulic connections. It is imperative that if there are any fittings, repairs etc. required these must be conducted by a fully certified and qualified hydraulics fitter.

8 RISK ASSESSMENT

Assessment Team: Norman Pesch, John Pesch, Sam Ramsden

Date of Assessment: 13/05/2022

Manufacturer: Norm Engineering Pty Ltd

Location: Brisbane

Contact Person: Norman Pesch

Attachment: 4-6T HYD. Quick Hitch

Weight: 60kg

Intended use: Remote Hitching **Construction material:** Grade 80 Bisalloy Steel

Air Operated: NO

Hydraulic Operated: YES

Manually operated: NO

NOTE: When assessing Risk, you MUST consider the following

Inherent Risk:

(Risk before ANY controls). I.e., Before guarding / safety features are fitted.

Residual Risk:

(Risk after controls are fitted). I.e., after guarding / safety features are fitted.

Non Standard Operating Risk:

(Cleaning, Maintenance). I.e., What other risks can these tasks create.

Predictable Misuse:

I.e., What risks could occur due to misuse of the attachment.

HAZARD INFORMATION

The plant must be assessed against the hazards listed for the probability of harm to operators working in close proximity and the environment.

Probability

- A – Common or repeating occurrence
- B – Known to occur or “It has happened”
- C – Could occur, “I’ve heard of it happening”
- D – Not likely to occur
- E – Practically impossible

Consequence

- 1 – Catastrophic – Fatalities
- 2 – Major – Major injury, LTI
- 3 – Moderate – Minor Injury
- 4 – Minor – First aid, slight injury
- 5 – Insignificant – Minimal risk of injury

	A	B	C	D	E
1	H	H	H	S	S
2	H	H	S	S	M
3	H	H	S	M	L
4	H	S	M	L	L
5	S	S	M	L	L

H = High

S = Significant

M = Medium

L = Low

Entanglement:

<p>Can anyone's hair, clothing gloves, necktie, jewellery, rags, and other materials become entangled with moving parts of plant, or materials in motion?</p> <p>It is possible to become entangled in moving parts if SOP's are not followed.</p>	Yes	No	A	<input type="checkbox"/>	1	<input type="checkbox"/>	High Significant Medium Low	<input type="checkbox"/>
	<input checked="" type="checkbox"/>	<input type="checkbox"/>	B	<input type="checkbox"/>	2	<input checked="" type="checkbox"/>		<input checked="" type="checkbox"/>
			C	<input type="checkbox"/>	3	<input type="checkbox"/>		<input type="checkbox"/>
			D	<input checked="" type="checkbox"/>	4	<input type="checkbox"/>		<input type="checkbox"/>
			E	<input type="checkbox"/>	5	<input type="checkbox"/>		<input type="checkbox"/>

Crushing:

<p>Can anyone be crushed due to falling, uncontrolled or unexpected movement of plant attachment or its load, lack of capacity to slow, stop or immobilise the plant, tipping or rolling over, parts of plant attachment collapsing, contact with moving parts during testing, inspection, maintenance, cleaning, or repair, thrown off, under or trapped between plant and materials or fixed structures?</p> <p>People in close proximity to the plant and plant attachment during operation could be crushed if the operator is not being sufficiently observant, or control over the plant is lost.</p>	Yes	No	A	<input type="checkbox"/>	1	<input checked="" type="checkbox"/>	High Significant Medium Low	<input checked="" type="checkbox"/>
	<input checked="" type="checkbox"/>	<input type="checkbox"/>	B	<input type="checkbox"/>	2	<input type="checkbox"/>		<input type="checkbox"/>
			C	<input checked="" type="checkbox"/>	3	<input type="checkbox"/>		<input type="checkbox"/>
			D	<input type="checkbox"/>	4	<input type="checkbox"/>		<input type="checkbox"/>
			E	<input type="checkbox"/>	5	<input type="checkbox"/>		<input type="checkbox"/>

Cutting, Stabbing, Puncturing:

<p>Can anyone be cut, stabbed, or punctured by coming in contact with moving plant or parts, sharp or flying objects, work pieces ejected, work pieces disintegrated, or other factors not mentioned?</p>	Yes	No	A	<input type="checkbox"/>	1	<input type="checkbox"/>	High Significant Medium Low	<input type="checkbox"/>
	<input type="checkbox"/>	<input checked="" type="checkbox"/>	B	<input type="checkbox"/>	2	<input type="checkbox"/>		<input type="checkbox"/>
			C	<input type="checkbox"/>	3	<input type="checkbox"/>		<input type="checkbox"/>
			D	<input type="checkbox"/>	4	<input type="checkbox"/>		<input type="checkbox"/>
			E	<input type="checkbox"/>	5	<input type="checkbox"/>		<input type="checkbox"/>

Striking:

<p>Can anyone be struck by moving objects due to plant or work pieces being ejected or disintegrated, mobility, uncontrolled or unexpected movement of the plant or other factors?</p> <p>People in close proximity to the plant and plant attachment during operation could be seriously hurt if they came into contact with the plant, or plant attachment if the operator is not being sufficiently observant, or control over the plant is lost.</p>	Yes	No	A	<input type="checkbox"/>	1	<input type="checkbox"/>	High Significant Medium Low	<input checked="" type="checkbox"/>
	<input checked="" type="checkbox"/>	<input type="checkbox"/>	B	<input checked="" type="checkbox"/>	2	<input checked="" type="checkbox"/>		<input type="checkbox"/>
			C	<input type="checkbox"/>	3	<input type="checkbox"/>		<input type="checkbox"/>
			D	<input type="checkbox"/>	4	<input type="checkbox"/>		<input type="checkbox"/>
			E	<input type="checkbox"/>	5	<input type="checkbox"/>		<input type="checkbox"/>

Slipping, Tripping, Falling:

<p>Can anyone using the plant or in the vicinity of the plant, slip, trip or fall due to the working environment or other factors? poor housekeeping, dust on the floor around machines, slippery or uneven work surfaces or lack of guardrails.</p> <p>People standing on the plant or plant attachment could slip or fall from it.</p>	Yes	No	A	<input type="checkbox"/>	1	<input type="checkbox"/>	High Significant Medium Low	<input type="checkbox"/>	
	<input checked="" type="checkbox"/>	<input type="checkbox"/>	B	<input type="checkbox"/>	2	<input type="checkbox"/>		<input checked="" type="checkbox"/>	<input type="checkbox"/>
			C	<input type="checkbox"/>	3	<input checked="" type="checkbox"/>		<input type="checkbox"/>	<input checked="" type="checkbox"/>
			D	<input checked="" type="checkbox"/>	4	<input type="checkbox"/>		<input type="checkbox"/>	<input checked="" type="checkbox"/>
			E	<input type="checkbox"/>	5	<input type="checkbox"/>		<input type="checkbox"/>	<input type="checkbox"/>

Shearing:

<p>Can anyone's body parts be cut off between two parts of the plant, or between a part of the plant and a work piece or structure? For example, on a metal guillotine can a finger fit under the guard.</p> <p>People not following SOP's or plant guidelines could become injured from misuses or working in the vicinity of the plant and plant attachment.</p>	Yes	No	A	<input type="checkbox"/>	1	<input checked="" type="checkbox"/>	High Significant Medium Low	<input type="checkbox"/>	
	<input checked="" type="checkbox"/>	<input type="checkbox"/>	B	<input type="checkbox"/>	2	<input type="checkbox"/>		<input checked="" type="checkbox"/>	<input type="checkbox"/>
			C	<input type="checkbox"/>	3	<input type="checkbox"/>		<input type="checkbox"/>	<input checked="" type="checkbox"/>
			D	<input checked="" type="checkbox"/>	4	<input type="checkbox"/>		<input type="checkbox"/>	<input type="checkbox"/>
			E	<input type="checkbox"/>	5	<input type="checkbox"/>		<input type="checkbox"/>	<input type="checkbox"/>

Friction:

<p>Can anyone be burnt due to contact with moving parts or surfaces of the plant, or material handled by the plant? For example, on the grinder is there more than 1 mm gap between the tool rest and the wheel?</p> <p>People could be burned if correct SOP's are not followed.</p>	Yes	No	A	<input type="checkbox"/>	1	<input type="checkbox"/>	High Significant Medium Low	<input type="checkbox"/>	
	<input checked="" type="checkbox"/>	<input type="checkbox"/>	B	<input type="checkbox"/>	2	<input type="checkbox"/>		<input type="checkbox"/>	<input type="checkbox"/>
			C	<input type="checkbox"/>	3	<input checked="" type="checkbox"/>		<input type="checkbox"/>	<input checked="" type="checkbox"/>
			D	<input checked="" type="checkbox"/>	4	<input type="checkbox"/>		<input type="checkbox"/>	<input type="checkbox"/>
			E	<input type="checkbox"/>	5	<input type="checkbox"/>		<input type="checkbox"/>	<input type="checkbox"/>

High Pressure Fluid:

<p>Can anyone come into contact with fluids under high pressure, due to plant failure or misuse of the plant?</p> <p>The plant attachment utilizes the plants high pressure hydraulic system, if a failure occurs it is possible to come into contact with high pressure fluid.</p>	Yes	No	A	<input type="checkbox"/>	1	<input type="checkbox"/>	High Significant Medium Low	<input type="checkbox"/>	
	<input checked="" type="checkbox"/>	<input type="checkbox"/>	B	<input type="checkbox"/>	2	<input checked="" type="checkbox"/>		<input type="checkbox"/>	<input checked="" type="checkbox"/>
			C	<input type="checkbox"/>	3	<input type="checkbox"/>		<input type="checkbox"/>	<input type="checkbox"/>
			D	<input checked="" type="checkbox"/>	4	<input type="checkbox"/>		<input type="checkbox"/>	<input type="checkbox"/>
			E	<input type="checkbox"/>	5	<input type="checkbox"/>		<input type="checkbox"/>	<input type="checkbox"/>

Electrical:

<p>Can anyone be injured by electrical shock or burnt due to damaged or poorly maintained leads or switches, water near electrical equipment, working near or contact with live electrical conductors, lack of isolation procedures or the factors not mentioned? For example, are any switches broken, is there a red emergency stop? Can each machine be locked off for repairs?</p>	Yes	No	A	<input type="checkbox"/>	1	<input type="checkbox"/>	High Significant Medium Low	<input type="checkbox"/>	
	<input type="checkbox"/>	<input checked="" type="checkbox"/>	B	<input type="checkbox"/>	2	<input type="checkbox"/>		<input type="checkbox"/>	<input type="checkbox"/>
			C	<input type="checkbox"/>	3	<input type="checkbox"/>		<input type="checkbox"/>	<input type="checkbox"/>
			D	<input type="checkbox"/>	4	<input type="checkbox"/>		<input type="checkbox"/>	<input type="checkbox"/>
			E	<input type="checkbox"/>	5	<input type="checkbox"/>		<input type="checkbox"/>	<input type="checkbox"/>

Dust:

Can anyone suffer ill health or injury due to exposure to dust? For example, cutting, living silica Lack of vision – External influences causing the dust. Plant operation causing the dust. Depending on the operation location of the plant and plant attachment dust being a nuisance could be a factor.	Yes	No	A	<input type="checkbox"/>	1	<input type="checkbox"/>	High Significant Medium Low	<input type="checkbox"/>
	<input checked="" type="checkbox"/>	<input type="checkbox"/>	B	<input type="checkbox"/>	2	<input checked="" type="checkbox"/>		<input type="checkbox"/>
			C	<input type="checkbox"/>	3	<input type="checkbox"/>		<input checked="" type="checkbox"/>
			D	<input type="checkbox"/>	4	<input type="checkbox"/>		<input type="checkbox"/>
			E	<input checked="" type="checkbox"/>	5	<input type="checkbox"/>		<input type="checkbox"/>
								<input type="checkbox"/>

Noise:

Can anyone suffer hearing discomforts while the plant is in use? For example, the plant is noisy, and it is difficult to hear. Hearing discomfort may be experienced by persons due to the noise generated by the plant. This can also lead to miscommunication.	Yes	No	A	<input type="checkbox"/>	1	<input type="checkbox"/>	High Significant Medium Low	<input type="checkbox"/>
	<input checked="" type="checkbox"/>	<input type="checkbox"/>	B	<input type="checkbox"/>	2	<input type="checkbox"/>		<input type="checkbox"/>
			C	<input checked="" type="checkbox"/>	3	<input type="checkbox"/>		<input type="checkbox"/>
			D	<input type="checkbox"/>	4	<input checked="" type="checkbox"/>		<input type="checkbox"/>
			E	<input type="checkbox"/>	5	<input type="checkbox"/>		<input type="checkbox"/>
								<input type="checkbox"/>

Vibration:

Can anyone suffer injury due to the vibration of the plant?	Yes	No	A	<input type="checkbox"/>	1	<input type="checkbox"/>	High Significant Medium Low	<input type="checkbox"/>
	<input type="checkbox"/>	<input checked="" type="checkbox"/>	B	<input type="checkbox"/>	2	<input type="checkbox"/>		<input type="checkbox"/>
			C	<input type="checkbox"/>	3	<input type="checkbox"/>		<input type="checkbox"/>
			D	<input type="checkbox"/>	4	<input type="checkbox"/>		<input type="checkbox"/>
			E	<input type="checkbox"/>	5	<input type="checkbox"/>		<input type="checkbox"/>
								<input type="checkbox"/>

Environmental:

Can the plant operation cause an environmental issue? For example – pollution, waste materials, noise.	Yes	No	A	<input type="checkbox"/>	1	<input type="checkbox"/>	High Significant Medium Low	<input type="checkbox"/>
	<input type="checkbox"/>	<input checked="" type="checkbox"/>	B	<input type="checkbox"/>	2	<input type="checkbox"/>		<input type="checkbox"/>
			C	<input type="checkbox"/>	3	<input type="checkbox"/>		<input type="checkbox"/>
			D	<input type="checkbox"/>	4	<input type="checkbox"/>		<input type="checkbox"/>
			E	<input type="checkbox"/>	5	<input type="checkbox"/>		<input type="checkbox"/>
								<input type="checkbox"/>

Risk Evaluation

Overall risk category of plant:	High	Significant	Medium	Low
---------------------------------	------	-------------	--------	-----

Risk Controls

Most Desirable

- | | | |
|---|--|---|
| ↓ | <ul style="list-style-type: none"> • Elimination • Substitution • Engineering Controls • Isolation • Administrative Controls • PPE | <ul style="list-style-type: none"> - The best way to eliminate the risk is to remove the hazard. - Substitute the hazardous plant with a safer part, alternative process. - Design modification, installation of guarding, automation/ventilation. - Isolate the plant, barricades, crossing, bunting, etc. - Permits, clearances, lock out systems, certification. - Short term control measure. |
|---|--|---|

Least Desirable

Hazard	Controls
Entanglement	<p>Engineering Controls – The body of the hitch is designed to minimize access to moving components to reduce risks of entanglement.</p> <p>Isolation – Ensure the operating and maintenance manual provided with the plant attachment recommends the operator of the plant always follows SOP. The operator must make everybody working in the vicinity of the attachment aware of the dangers and only operate if people are a safe distance away.</p> <p>PPE – Ensuring all people who will be in the vicinity of the plant attachment during operation be wearing clothes that mitigate the chances of becoming entangled by accident.</p>
Crushing, Striking	<p>Isolation – Ensure the operating and maintenance manual provided with the plant attachment recommends the operator of the plant always follows SOP. The operator must make everybody working in the vicinity of the attachment aware of the dangers and only operate if people are a safe distance away.</p> <p>PPE – The use of the correct PPE for the worksite will minimize the damage caused by an incident. A hard hat, steel cap boots and tough worksite clothes as an example.</p> <p>PPE – The use of high visibility PPE will help reduce the case of incidents occurring from impaired vision or operator distraction.</p>
Slipping, Tripping, Falling	<p>Isolation – The plant attachment has NOT been designed to stand on unless entering or exiting the plant. This will be stated in the operating and maintenance manual. It is the responsibility of the operator to ensure that no persons stand on the plant attachment.</p> <p>PPE – Wearing the correct work boots will reduce chances of slipping.</p>
Shearing	<p>Engineering Controls – The body of the hitch is designed to minimize access to moving components to reduce risks of shearing.</p> <p>Isolation – Ensure the operating and maintenance manual provided with the plant attachment recommends the operator of the plant always follows SOP. The operator must make everybody working in the vicinity of the attachment aware of the dangers and before moving the plant ensure people are safe distance away.</p> <p>Administrative Controls – A warning sticker should be placed in visible position on the plant attachment highlighting the potential risk.</p>

<p>High Pressure Fluid</p>	<p>Engineering Controls – The routing of the hydraulic hoses and the design of the plates which guard the hydraulic motor minimize the risk of the hydraulic failure and exposure to high pressure fluids.</p> <p>Administrative Controls – The manual will address correct maintenance schedules for the plant attachment hydraulics to reduce the risk associated with hydraulic component failure.</p> <p>Administrative Controls – A warning sticker should be placed in a visible position on the plant attachment highlighting the potential risk.</p>
<p>Dust</p>	<p>Isolation and Administrative Controls – To reduce the hazards associated with dust, the manual should instruct the operator to consider their working environment and operate in a manner to reduce the risk of dust being kicked up. This can be managed by setting and maintaining a sensible speed.</p> <p>PPE – If the environment is such that the dust cannot be sufficiently controlled, the onsite supervisor should ensure all workers are wearing the correct PPE.</p>
<p>Noise</p>	<p>PPE – To reduce the risk associated with excessive noise the correct PPE should be worn whilst operating or being within a vicinity of the plant and plant attachment during operations.</p>

Any Modification to Plant Attachment Voids Risk Assessment

Purchaser and User are required to conduct their own risk assessment to identify hazards prior to use.

This risk assessment does not necessarily cover all possible hazards associated with this product and should be utilized in conjunction with the purchasers and users individual risk assessments to identify all environmental, health, and safety risks associated with specific tasks, locations, and personnel.

9 PARTS

QUALITY BACKUP

*We manufacture 90% of our parts inhouse.
This means we can get your parts to you... quickly.*

Refer to the exploded diagram included in this manual.

9.1 ORDERING PARTS

For ordering parts contact either your dealer or Norm Engineering directly. Contact details are included at the front of this manual. To assist, note the details of your hitch in the spaces provided under *Section 9.1.1 Reference Information*.

9.1.1 REFERENCE INFORMATION

Always refer to the model and serial number when ordering parts or requesting from you dealer. The serial number for this product is located on the identification place of your hitch.

Model Number:

.....

Make:

.....

Serial Number:

.....

Date Purchased:

.....

10 PARTS LIST

When ordering replacement parts, please include the following information:

- The machine make and model.
- The serial number on the attachment.
- The item number, as indicated by the following figures and tables.
- Parts with a part number of “.:” indicate a component that varies dependent on machine make and model. A serial number and item number is essential if ordering these parts.

Items numbers with a “R” before the number indicate parts that require specialty tools and some knowledge in fabrication and welding to replace.

STANDARD PARTS LIST

Item	Quantity	Description	Refer to Diagram
1	1	Hitch body	1
2	1	Sliding jaw	1
3	1	Secondary locking arm	1
4	1	Locking collar	1
5	1	Pivot pin	1
6	1	Hydraulic locking cylinder	1
7	1	Pilot operated check valve	1
8	1	Sliding jaw timing spring	1
9	2	Secondary locking spring	1
10	2	Pivot pin internal circlip	1
11	2	Spring mount countersunk bolt	1
12	2	Spring mount nyloc nut	1
13	1	Locking system nyloc nut	1
14	1	Locking system half nut	1
15	1	Locking collar grub screw	1

Diagram 1

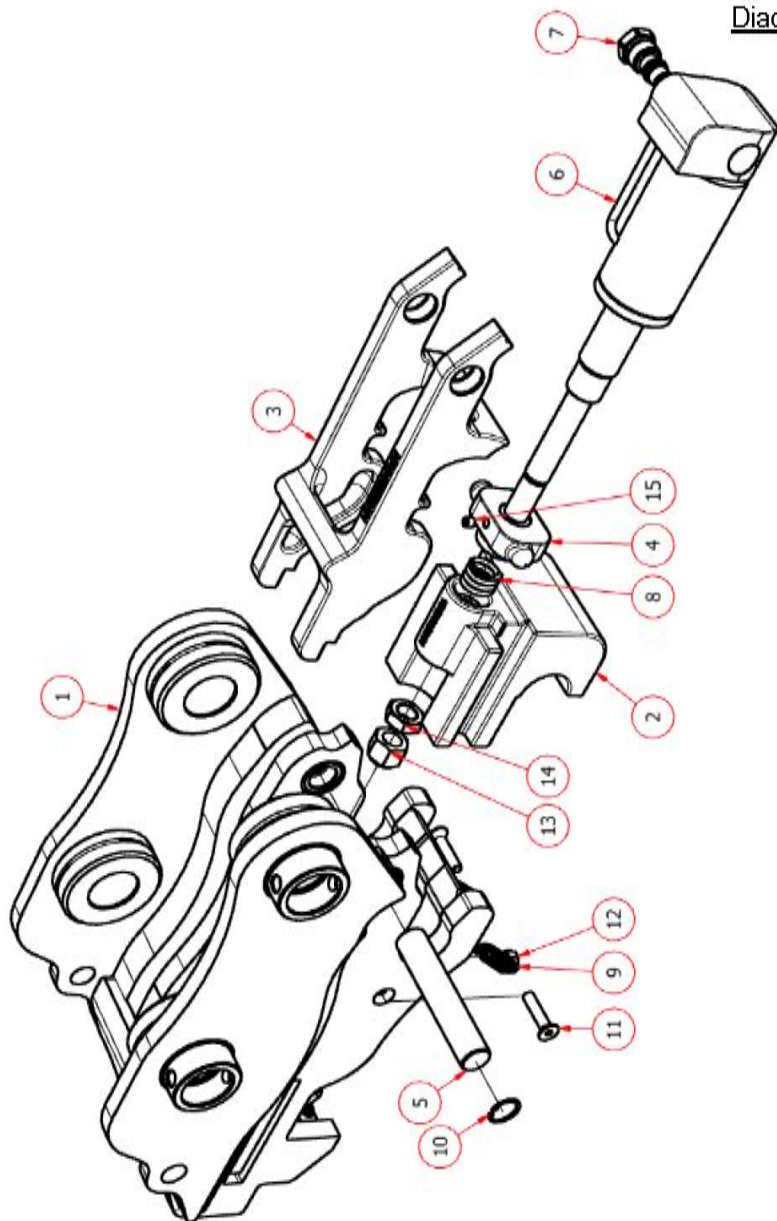

APPENDICES

A.1 SAFETY SIGN LOCATIONS

Item	Description
1	Warning Pinch point
2	Warning This machine is fitted with an aftermarket hitch. Collision between the attachment and boom may be possible
3	Notice This automatic quick coupler complies with both AS 4772-2008 and ISO 13031.2. It DOES NOT require a safety pin.
4	Danger Read the manual



ITEM 1



ITEM 2



ITEM 3

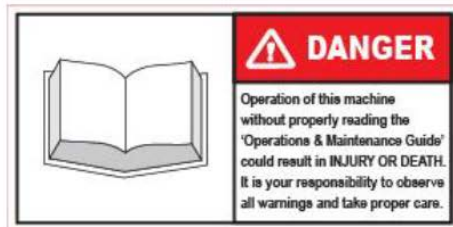

Item 4

Instructions

- Keep all safety signs clear and legible.
- Replace all missing, illegible, or damaged safety signs.
- When replacing parts which have safety signs attached make sure the replacement part has the safety sign.

A.2 MAINTENANCE SCHEDULE

Section 1 Prior to use checks				
<i>Recommended checks described in Section 7.1</i>				
Date	Time	Operator Safety Checks (name of operator or competent person)	Name of company	Signature
	am/pm			
	am/pm			
	am/pm			
	am/pm			
	am/pm			
	am/pm			

Section 2 Weekly and routine maintenance and safety checks					
<i>Recommended checks described in Section 7.2 and 7.3</i>					
Date	Hour meter	Name of inspector	Company	Qualifications	Signature
	h				
	h				
	h				
	h				
	h				
	h				

Section 3 || Third party maintenance and safety checks*Recommended checks described in Section 7.4*

Date	Hour meter	Name of inspector	Company	Qualifications	Signature
	h				
	h				
	h				
	h				
	h				
	h				

Section 4 || Faults, difficulties, and problems log*Record all issues that are discovered during any of the recommended maintenance checks.*

Date	Time	Fault, difficulty, or problem	Company	Repairs	
				Comment	Signature
	am/pm				
	am/pm				
	am/pm				
	am/pm				
	am/pm				
	am/pm				

11 WARRANTY

11.1 DEFINITION

“Dealer” means a dealer that purchases products directly from Norm Engineering Pty Ltd.

“End consumer” means a consumer that purchases products either directly from Norm Engineering Pty Ltd or directly from a “dealer” as defined above.

“Products” includes goods and services.

11.2 WARRANTY

Norm Engineering Pty Ltd welcomes you as a purchaser of its products. All Norm Engineering products are designed to ensure the highest standards, reliability, and performance.

Norm Engineering Pty Ltd warrants hydraulic cylinders against defects in manufacture for a period of twelve months from date of sale by the dealer or Norm Engineering Pty Ltd to the end consumer. The warranty in relation to hydraulic cylinders ceases upon the occurrence of damage to the piston rod of the hydraulic cylinder.

No warranty applies to hoses, tubes, and fittings in relation to any of the products.

Norm Engineering Pty Ltd warrants all its other products against defects in manufacture for a period of twelve months from the date of sale by the dealer or Norm Engineering Pty Ltd to the end consumer.

Norm Engineering Pty Ltd will, subject to the terms of this warranty, in relation to defective goods:

- a) replace the defective goods at no cost to the end consumer; or
- b) repair the defective goods at no cost to the end consumer; or
- c) pay the cost of having the defective goods repaired.

Norm Engineering Pty Ltd will, subject to the terms of this warranty, in relation to defective services:

- a) supply the services again to the end consumer at no cost to the end consumer; or
- b) pay the cost of having the service supplied again to the end consumer.

Warranty claims may be sent either to Norm Engineering Pty Ltd., P.O. Box 178, Mt Ommaney, Qld. 4074 or to the dealer.

All warranty periods shall commence from the date of sale by Norm Engineering Pty Ltd or the dealer to the end consumer. It is the end consumer's responsibility to establish the date of sale of the product to the end consumer by the dealer.

The end consumer may establish the date of sale by producing to Norm Engineering Pty Ltd the dated contract of sale between the end consumer and the dealer with its warranty claim.

If the end consumer is not able to establish the date of sale of the product to the end consumer by the date of its warranty claim, the warranty period shall be deemed to commence from the date of sale of the product by Norm Engineering Pty Ltd to the dealer.

This warranty will not apply if the end consumer does not use the product in accordance with Norm Engineering Pty Ltd's recommendation.

This warranty will not apply if the end consumer does not use products applied or fitted to any machine, equipment, or plant, in accordance with Norm Engineering Pty Ltd's operating recommendation for the product.

This warranty does not apply to any loss or damage caused through consequential neglect. Unless the end consumer indicates to Norm Engineering Pty Ltd prior to purchasing the product that it intends to use the product for a particular purpose, there is no implied warranty that the product will fit for that particular purpose. Ask Norm Engineering for clarification of the intended use is not included in the manual.

Only a dealer authorised in writing, or issued with an order number, by Norm Engineering Pty Ltd may carry out warranty repairs. Prior written approval must be obtained from Norm Engineering Pty Ltd before warranty repairs are carried out. Norm Engineering Pty Ltd will not recognise any warranty claim for reimbursement of repair costs unless the repairs have been carried out by an authorised dealer with prior written approval from Norm Engineering Pty Ltd to carry out the repairs.

Norm Engineering Pty Ltd limits its liability, as follows:

1) Pursuant to Section 68A of the Trade Practices Act 1974, this clause applies in respect of any of the goods or services supplied under this contract which are not of a kind ordinarily acquired for personal, domestic, or household use or consumption, provided that this clause will not apply if the end consumer establishes that reliance on it would not be fair and reasonable.

2) Liability for breach of a condition or warranty implied into this contract by the Trade Practices Act 1974 other than a condition implied by Section 69 is limited:

a) In the case of goods, to any one of the following as determined by Norm Engineering Pty Ltd:

i. the replacement of goods

ii. the repair of the goods

iii. the payment of the cost of having the goods repaired, excluding travelling and freight charges.

b) In the case of services, to any one of the following as determined by Norm Engineering Pty Ltd.

i. the supplying of the services again; or

ii. the payment of the cost of having the services supplied again

Expenses incurred by the end consumer in connection with making a warranty claim shall be borne by the end consumer unless otherwise agreed by Norm Engineering Pty Ltd.

To the extent permitted by law, all implied conditions, and warranties in the contract of sale between Norm Engineering Pty Ltd and the end consumer are hereby excluded.

The benefits conferred by this warranty on the end consumer are in addition to all other legal rights and remedies that the end consumer has in respect of the products.

Contracts of sale for products, and this warranty are submitted to the exclusive jurisdiction of the courts of Queensland.



WARRANTY NOTICE

DEALER:

STATE: SIGNED:

END CONSUMER:

NAME:

ADDRESS:

.....

.....

STATE: POSTAL CODE:

PHONE: SIGNED:

DATE OF SALE TO THE END CONSUMER:/...../.....

DESCRIPTION OF PRODUCTS:

.....

.....

.....

SERIAL NO:

DELIVERY DOCKET NO:

DELIVERY DATE:/...../.....

NOTE: THIS FORM IS TO BE COMPLETED BY THE DEALER
AND RETURNED TO: NORM ENGINEERING - P O BOX 178
MT OMMANEY, BRISBANE, QUEENSLAND, AUSTRALIA, 4074