



# 4-IN-1 LOADER STYLE BUCKET

## OPERATING & PARTS MANUAL



SALES@NORMENG.COM.AU • 07 3376 3177 • WWW.NORMENG.COM.AU

### BRISBANE

PH: 07 3376 3177  
FAX: 07 3376 3201  
787 BOUNDARY ROAD  
DARRA QLD 4076

### MELBOURNE

PH: 03 9775 1965  
FAX: 03 9786 9102  
2/45 FRANKSTON GARDENS DRIVE  
CARRUM DOWNS VIC 3201

# Contents

1	Introduction .....	1
2	Safety Definitions: Terms and Symbols.....	2
3	Safety Instructions .....	3
3.1	Important Points .....	5
4	PreDelivery .....	6
4.1	Check Pickup Fit .....	6
4.2	Check Range of Motion.....	6
4.3	Check Hydraulic Hoses .....	7
4.4	Hydraulic Cylinder Running-in.....	7
5	Assembly Instructions .....	8
5.1	Hitching Up the Loader Bucket .....	8
5.2	Removing the Loader Bucket.....	9
6	Specified Operations.....	10
6.1	The Closed Bucket.....	10
6.2	The Dozer Blade .....	10
6.3	The Back Blade .....	11
6.4	The Open and Closing Instructions.....	11
7	Safe Operating Limits .....	11
8	Maintenance and Care.....	12
8.1	Hydraulics.....	12
8.2	Prior to Use .....	12
8.3	Monthly.....	13
8.4	Bolt-On-Cutting Edges (Only applies to models with bolt-on edges) 13	
8.4.1	Replacing the Front Edge .....	14
8.4.2	Replacing the Rear Edge and Bulldozer Edge .....	15
9	Risk Assessment .....	16
10	Parts .....	22

10.1	Ordering Parts .....	22
10.1.1	Reference Information.....	22
11	Parts List .....	23
12	Appendices.....	26
12.1	Safety Sign Locations .....	26
A.2	Maintenance Schedule Sample.....	27
13	Warranty.....	29
13.1	Definition .....	29
13.2	Warranty.....	29

# 1 INTRODUCTION



## **Compact Loader 4in1 Bucket**

Congratulations on purchasing a Norm Engineering Pty Ltd attachment. We have designed this 4in1 loader style bucket for a long, productive, and safe life. Your attachment will provide you with years of service provided regular maintenance and correct usage is applied.

This manual offers a guide on how to safely assemble, mount, operate and maintain your 4in1 loader style bucket. While the manual attempts to cover most situations, there are many unforeseen risks and events that are not included due to the capability of the 4in1 loader style bucket. On this basis the owner and/or operator must determine if this attachment is suited for a particular purpose.

Norm Engineering Pty Ltd can accept no responsibility or liability for how you operate your equipment: we can only provide warning notes and safety precautions in relation to the standard operation of the 4in1 loader style bucket.

The illustrations and data used in this manual were current at the time of printing but due to possible engineering and/or production changes, this product may vary slightly. Norm Engineering Pty Ltd reserves the right to redesign and/or change components as may be necessary without notification.

## 2 SAFETY DEFINITIONS: TERMS AND SYMBOLS

We will use the ANSI Z535.4-2011(R2017) standard for the definitions of signal words as described in conjunction with colours red, orange, and yellow. These are used with the Safety Alert Symbol:

- **Signal word:** Are defined as the words used in the signal word panel. The signal words for hazard alerting signs are “DANGER”, “WARNING”, and “CAUTION”. Safety notice signs use the signal word “NOTICE”. Safety instruction signs use signal words that are specific to the situation.
- **DANGER:** Indicates a hazardous situation, which, if not avoided, **will** result in death or serious injury. This signal word is to be limited to the most extreme situations. (White letters on a red background) 
- **WARNING:** Indicates a hazardous situation, which, if not avoided, **could** result in death or serious injury. (Black letters on an orange background) 
- **CAUTION:** Indicates a hazardous situation, which, if not avoided, **could** result in minor or moderate injury. (Black letters on a yellow background) 
- **NOTICE:** Indicates information considered important, but **not** hazard-related (e.g., messages relating to property damage). (White letters on a blue background) 
- **SAFETY INSTRUCTIONS:** Indicates a type of safety sign, where specific **safety-related instructions** or **procedures** are described. More definitive signal words are encouraged, where practical (e.g., SAFE SHUTDOWN PROCEDURE, SAFE OPERATING PROCEDURE). (White letters on a green background) 

### 3 SAFETY INSTRUCTIONS



#### **WARNING**

Obey all the safety instructions listed in this section and throughout this manual. Failure to follow instructions could result in death or serious injury.

#### **NOTICE**

Before attempting any type of assembly operation, maintenance, or other work on or near this product:

- READ and COMPLETELY UNDERSTAND:
  - This manual,
  - The manuals provided with the power unit being used with this attachment.
- Read and understand all safety signs associated with the equipment being used.
- Know all your controls and know how to quickly stop all power unit movement, the attachment movement, and the engine in case of an emergency.

**SAFETY IS YOUR RESPONSIBILITY AS THE OPERATOR OF THE EQUIPMENT**

Inappropriate and/or irresponsible use of a 4in1 loader style bucket may cause serious injury and trauma. The operator must have all relevant industry competencies, qualifications, certificates and/or licenses.

The operator must understand their responsibilities under the relevant acts and regulations of the governing body. Failure to comply with your legal obligations under the act may result in prosecutions against you.

As the equipment operator you are responsible to familiarise yourself, and anyone else who will assemble, operate, maintain, or work around this product with the safety information contained within this manual. You must make certain that all operators and maintenance personnel have a complete understanding of the full and exact contents of this manual and those of the power unit.

There are usually specific precautions and steps in the loader operating manual to be taken to ensure your safety prior to engaging the 4in1 loader style bucket.

Conduct a job site survey during the planning phase of any construction project to identify potential hazards and develop and implement appropriate control measures to protect workers.

Accidents are preventable if the equipment operator is careful and responsible. No accident prevention program can be successful unless there is a wholehearted commitment and cooperation of the person who is directly responsible for the operation of the equipment.

Make sure anyone who will be installing, maintaining, repairing, removing, and/or storing this product applies the Workplace Health and Safety Act requirements. This includes ensuring that the person has been instructed in the safe operation of this product and of the power unit to which this attachment is likely to be attached.

Know and follow good work practices, some of these include:

- To optimise the physical environment such as having a well-lit, level surface that is clean and dry to work on.
- Use properly grounded, test and tagged electrical outlets and tools.
- Use the right tool for the job at hand.
- Make sure that your tools are in good condition for performing the required function.
- When using tools, wear the protective equipment specified by the tool manufacturer (hardhat, safety glasses, work gloves, protective shoe...)
- When the 4in1 bucket has been out in the sun, remember to wear protective gloves as the metal will be hot to touch.
- Before starting, know the job duration, job complexity, and best procedure.
- Ensure workers have the capacity to do the job.
- Check that all hazards have been identified and control measures implemented.
- Clear communication so everyone present knows what is happening.
- Clear emergency stop procedure so there is no confusion in an emergency.
- Ensure the use of tyre stoppers and securing framework to stop the plant and plant attachment moving during maintenance.

## 3.1 IMPORTANT POINTS

When your power unit is used during any type of assembly, operation, maintenance, or other work on or near this product:

- Before leaving the operator's station or before beginning any type of work on this product, lower this product to the ground, apply your loader's parking brake, stop the engine, remove the starter key, wait for all moving parts to stop and then relieve all pressure in the hydraulic lines. Refer to your loader's operating manual for instructions on preparing the equipment for hitching up an attachment and relieving hydraulic pressure in lines.
- Know your loader's safe lifting and operating capacity and the weight of this product. (Check the parent machines operator manuals for safe operating limits).
- Only allow the operator to be around the power unit or this product when either is in motion. Ensure work area is clear of all personnel.
- Apply all safety guidelines in relation to the operator and the equipment.
- Only operate controls from the operator's station.
- Maintain operator presence at all times when the engine is running, or the product is raised on the power unit.
- Reduce speeds when additional weight and width need to be considered especially over rough ground.
- Consider the operating environment if dust is a concern reduce the machine speeds.
- Whilst in motion keep the product close to the ground and under control.



## 4 PREDELIVERY

The following steps should be performed when fitting this attachment to a power unit for the first time. Failure to perform these checks may lead to damage of the attachment, the power unit and be a risk to safety. Warranty claims that arise as a result of skipping these steps may be challenged.

### 4.1 CHECK PICKUP FIT

Perform '5.1 Hitching Up the Loader Bucket' to check how the attachment fits the coupler. Check for the following:

- Do the pins lock?
- Is it a snug fit?

### 4.2 CHECK RANGE OF MOTION

Carefully go through the attachment and parent machines full range of motion together. If unexpected contact occurs, contact Norm Engineering to discuss. Due to the capabilities of this product some contact with the machine may be unavoidable. In this case place the warning sticker provided on the attachment and inform the owner/operator.



## 4.3 CHECK HYDRAULIC HOSES

If you are unsure how to route the hydraulic hoses, contact Norm Engineering. Connect hoses and once again thoroughly check full range of motion to make sure:

- They **DON'T** pull tight.
- They **DON'T** have excessive length.

If the hose length is not correct, call Norm Engineering first for assistance.

## 4.4 HYDRAULIC CYLINDER RUNNING-IN

To maximise the life of the unit, it must be run in for a period. To carry out the running in procedure, suspend the bucket just off the ground in a horizontal working position. Ensure there are no bystanders within the nominated radius as defined in the risk assessment completed prior to commencing any works.

Operate the hydraulic cylinders to their open and closed positions five times and note the sensitivity of the operation. If there are any issues with the cylinder movements call Norm Engineering first for assistance.

## 5 ASSEMBLY INSTRUCTIONS



### WARNING

Obey all instructions listed in this section of the manual. Failure to follow the instructions listed below could lead to serious injuries.

For any assistance with the following processes, please contact Norm Engineering.

### 5.1 HITCHING UP THE LOADER BUCKET



### DANGER

All safety precautions pertaining to both the power unit and the 4in1 loader style bucket need to be followed. Sufficient planning should be made prior to any work commencing in case of an emergency situation.

**Step one:** Before beginning any work on this product, lower the product to the ground on a firm level surface that is large enough to accommodate this product, the power unit and all workers involved in the hitching up the 4in1 loader style bucket.

**Step two:** Refer to your loader's operating manual for instructions on hitching up this attachment. Visually inspect to ensure the attachment is fully engaged to the power unit hitch.

**Step three:** Engage the locking mechanism. A visual inspection should be performed to confirm all locking systems are secured. Give the 4in1 loader style bucket a few short sharp movements close to the ground to ensure it is engaged.

**Step four:** Rest the attachment on the ground and refer to the loader operating manual to release the pressure in the hydraulic system.

**Step five:** Connect the hydraulic couplings on the 4in1 loader style bucket to the power unit couplings following all safety precautions specified in the power units operating manual.

**Step six:** Start the machine and cycle the 4in1 loader style bucket cylinder several times before taking it near other personnel.

## 5.2 REMOVING THE LOADER BUCKET



All safety precautions pertaining to both the power unit and the 4in1 loader style bucket need to be followed. Sufficient planning should be made prior to any work commencing in case of an emergency situation.

**Step one:** Remove the machine from anywhere near other personnel and onto a firm level surface large enough to safely accommodate this product, the loader and all workers involved in removing the 4in1 loader style bucket.

**Step two:** Rest the 4in1 loader style bucket on the ground.

**Step three:** Disconnect the attachment's hydraulic couplings from the power unit following all safety precautions. Refer to your loader's operating manuals.

**Step four:** Disengage the locking mechanism. A visual inspection should be performed to make sure the 4in1 loader style bucket is fully disengaged.

**Step five:** Refer to your loader's operating manual for instructions on removing the attachment and confirm the hitch is fully disengaged from the 4in1 loader style bucket. Store safely.

## 6 SPECIFIED OPERATIONS

### **DANGER**

The operator of the power unit needs to make sure that the area that is to be worked on is a safe working environment following all the safety requirements. Refer to any risk assessment or survey that has been conducted to ensure potential hazards have required controls to ensure safety for workers

### 6.1 THE CLOSED BUCKET

The 4in1 bucket is to be used for stockpiling, loading, digging, dumping, scraping, and carrying. It is not to be used for any other purpose.

#### **NOTICE**

ENSURE the load capacity of the bucket is within the constraints of the power unit.

ENSURE the bucket has the capacity to pick up or carry the objects.

### **DANGER**

ENSURE that the bucket carries only what it has been designed to carry – this does NOT include people.

### 6.2 THE DOZER BLADE

With the bucket open, the dozer blade can be used to push unwanted material in a controlled manner.

#### **NOTICE**

ENSURE the cut can be managed by the bucket. Be aware that too deep a cut has the potential to over stress the bucket.

ENSURE you travel safely and at a speed appropriate to prevent damage if an unseen obstacle is hit.

### **WARNING**

It is possible to jar the neck, back and shoulders when hitting an unseen object.

## 6.3 THE BACK BLADE

Used with the bucket open, the back blade can be used for levelling, scraping, and clean-up work.

### NOTICE

ENSURE the bucket is closed proper before attempting to rip at an obstacle.

ENSURE the bucket is used for the correct purposes only – NOT as a lifting point.

### WARNING

It is possible to back into other people. Jarring of the neck, back and shoulders may occur if an obstacle is hit whilst operating the power unit in reverse.

## 6.4 THE OPEN AND CLOSING INSTRUCTIONS

This action can be used for scooping up fines into the bucket and also dumping the load into a truck.

### NOTICE

ENSURE appropriate use of the closing and opening action, which does not include attempting to clamp objects with the bucket.

### CAUTION

ENSURE when moving clamped material that this is clear of personnel below or near the area, as there is a danger of material releasing and falling

ENSURE that the bucket has the capacity to pick up or carry the objects.

ENSURE the bucket is closed prior to carrying the materials.

### WARNING

Objects may fall from the open bucket. Personnel may be impacted if the operator attempts to carry an oversized load.

## 7 SAFE OPERATING LIMITS

### WARNING

Refer to the parent equipment manual to ensure you follow all the limits specified. Do not exceed load limits.

## 8 MAINTENANCE AND CARE



### WARNING

Repairs and maintenance must be carried out safely to prevent injury.

While conducting repairs and maintenance, the 4in1 loader style bucket must be removed from the loader and hydraulic pressure released. Refer to your loader's operating manual. The 4in1 loader style bucket must be supported and secure on a firm base. Be aware of fluids under pressure and take safety precautions to protect from injury.

### 8.1 HYDRAULICS



### WARNING

Read and understand all safety requirements prior to beginning any maintenance to any hydraulic connections. It is imperative that if there are any fittings, repairs etc. required these must be conducted by a fully certified and qualified hydraulics fitter.

### 8.2 PRIOR TO USE

Prior to use, the 4in1 loader style bucket shall be visually inspected to verify the attachment is in an operational state. The inspection will check for:

- Signs of wear, including corrosive and abrasive wear.
- Clean the bucket of any excessive material build up. In particular, ensure there is no material built up in the towers behind each cylinder. Bent cylinder rods, due to material build up, are not covered under warranty.
- Welds are not damaged, cracked or worn.
- Hydraulic hoses, fittings and cylinders are in good conditions with no leaks.
- All fasteners are in place and correctly torqued.
- 4in1 loader style bucket signs are in place, in good order, and legible.
- Grease all fittings – this needs to be performed on a daily basis.
- Inspect cutting edges for wear or damage and rotate (or replace) them if necessary. See Section 8.4.

Note: Some of the hydraulic cylinders will have two grease fittings on the cross tube end of the barrel section of the cylinder. Only one of these two fittings need to be greased.

## 8.3 MONTHLY

The following activities are recommended:

- All pins must be greased at regular intervals.
- Fittings, hoses, and hydraulics must be checked to make sure there are no leaks.
- Pins and bushes must be inspected and replaced before wear damages the 4in1 loader style bucket structure.
- Inspect and replace worn parts such as cutting edges and wear plates before wear damages the structure of the bucket.
- Inspect and replace worn teeth before wear occurs through to the tooth adaptors
- Organise for a certified and qualified hydraulics fitter to inspect and replace hydraulic hoses and seals in the hydraulic parts as necessary. For additional information refer to section '13 Warranty'.

## 8.4 BOLT-ON-CUTTING EDGES (ONLY APPLIES TO MODELS WITH BOLT-ON EDGES)



Failure to obey the following procedures could result in death or serious injury.

Do NOT use blocking made of concrete blocks, logs, buckets, barrels, or any other material that could suddenly collapse or check positions. Do NOT use wood or steel blocking that shows any signs of material decay. Do NOT use blocking that is warped, twisted, or tapered.

Ensure a safe working environment proper to undertaking any replacements to the 4in1 loader style bucket.



## 8.4.1 REPLACING THE FRONT EDGE

**Step one:** Park your loader on a level surface with this product properly attached.

**Step two:** Refer to the loader operating manual for safety precautions regarding making disengagements for enabling replacements of parts on the 4in1 loader style bucket.

**Step three:** Lower this product onto preplaced blocking. It must be sufficient to support the bucket.

**Step four:** Remove all nuts from the bolts that secure the cutting edge to the floor. Begin in the centre and remove the end nuts last. Use of a pipe wrench or hand grinder may be necessary to remove extremely worn or damaged nuts.

**Step five:** Remove the cutting edge and either turn the cutting edge end-for-end or, if this process has already occurred, properly dispose of the cutting edge. Properly dispose of all nuts and bolts.

**Step six:** Clean the surface of the floor that the cutting edge will attach to. If installing a reversed cutting edge, ensure the attached surface is clean. Failure to properly clean both surfaces may lead to the cutting edge fasteners loosening over time.

**Step seven:** Install the new or reversed cutting edge by loosely securing each end of the cutting edge with a new bolt and nut. **Do not** reuse the old nuts and bolts.

**Step eight:** Install all the remaining new nuts and bolts and tighten all the new nuts to the required torque for the 4in1 loader style bucket. Note the required torque is 60 ft. Lbs.

## 8.4.2 REPLACING THE REAR EDGE AND BULLDOZER EDGE

**Step one:** Ensure a safe working environment, enabling access to the edge retaining bolts and required clamps.

**Step two:** Start your loader, raise the bucket, and open the floor. Engage the loader arm lock and make sure all safety instructions are followed as per the power unit operating manual prior to commencing the next step.

**Note,** this includes engaging the loader arm locks **before** commencing any work on the bucket.

**Step three:** Remove all nuts from the bolts that secure the cutting edge to the floor or rear of the bucket. Begin in the centre and ensure you remove the outside nuts last. Use of a pipe wrench or hand grinder may be required to remove extremely damaged or worn nuts.

**Step four:** Remove the cutting edge and either turn the cutting edge end-for-end or, if this process has already occurred, properly dispose of the cutting edge. Properly dispose of all nuts and bolts.

**Step five:** Clean the surface of the floor (or back skin) that the cutting edge will attach to. If installing a reversed cutting edge, ensure the attached surface is clean. Failure to properly clean both surfaces may lead to the cutting edge fasteners loosening over time.

**Step six:** Install the new or reversed cutting edge by loosely securing each end of the cutting edge with a new bolt and nut. **Do not** reuse the old nuts and bolts.

**Step seven:** Install all the remaining new nuts and bolts and tighten all the new nuts to the required torque for the loader bucket. Note the required torque is 60 ft. Lbs.

# 9 RISK ASSESSMENT

**Assessment Team:** Norman Pesch, John Pesch, Sam Ramsden

**Date of Assessment:** 10/05/2022

**Manufacturer:** Norm Engineering Pty Ltd

**Location:** Brisbane

**Contact Person:** Norman Pesch

**Attachment:** 4in1 Loader Style Bucket

**Weight:** 450-705kg

**Intended use:** Material Handling

**Construction material:** Steel

**Air Operated:** NO

**Hydraulic Operated:** YES

**Manually operated:** YES

*NOTE: When assessing Risk, you MUST consider the following*

Inherent Risk:

(Risk before ANY controls). I.e., Before guarding / safety features are fitted.

Residual Risk:

(Risk after controls are fitted). I.e., after guarding / safety features are fitted.

Non Standard Operating Risk:

(Cleaning, Maintenance). I.e., What other risks can these tasks create.

Predictable Misuse:

I.e., What risks could occur due to misuse of the attachment.

## HAZARD INFORMATION

The plant must be assessed against the hazards listed for the probability of harm to operators working in close proximity and the environment.

### Probability

- A – Common or repeating occurrence
- B – Known to occur or “It has happened”
- C – Could occur, “I’ve heard of it happening”
- D – Not likely to occur
- E – Practically impossible

### Consequence

- 1 – Catastrophic – Fatalities
- 2 – Major – Major injury, LTI
- 3 – Moderate – Minor Injury
- 4 – Minor – First aid, slight injury
- 5 – Insignificant – Minimal risk of injury

	A	B	C	D	E
1	H	H	H	S	S
2	H	H	S	S	M
3	H	H	S	M	L
4	H	S	M	L	L
5	S	S	M	L	L

H = High

S = Significant

M = Medium

L = Low

**Entanglement:**

<p>Can anyone's hair, clothing gloves, necktie, jewellery, rags, and other materials become entangled with moving parts of plant, or materials in motion?</p> <p><b>Persons working in close proximity to the plant attachment may become entangled in moving components, i.e., hydraulics, etc.</b></p>	Yes	No	A	<input type="checkbox"/>	1	<input type="checkbox"/>	High Significant Medium Low	<input type="checkbox"/>	
	<input checked="" type="checkbox"/>	<input type="checkbox"/>	B	<input type="checkbox"/>	2	<input type="checkbox"/>		<input checked="" type="checkbox"/>	<input checked="" type="checkbox"/>
			C	<input checked="" type="checkbox"/>	3	<input type="checkbox"/>		<input type="checkbox"/>	<input type="checkbox"/>
			D	<input type="checkbox"/>	4	<input type="checkbox"/>		<input type="checkbox"/>	<input type="checkbox"/>
			E	<input type="checkbox"/>	5	<input type="checkbox"/>		<input type="checkbox"/>	<input type="checkbox"/>

**Crushing:**

<p>Can anyone be crushed due to falling, uncontrolled or unexpected movement of plant attachment or its load, lack of capacity to slow, stop or immobilise the plant, tipping or rolling over, parts of plant attachment collapsing, contact with moving parts during testing, inspection, maintenance, cleaning, or repair, thrown off, under or trapped between plant and materials or fixed structures?</p> <p><b>Persons working in close proximity to the plant attachment could be crushed with the movement of the hydraulics, motion of the bucket or if SOP is not followed.</b></p>	Yes	No	A	<input type="checkbox"/>	1	<input checked="" type="checkbox"/>	High Significant Medium Low	<input checked="" type="checkbox"/>	
	<input checked="" type="checkbox"/>	<input type="checkbox"/>	B	<input type="checkbox"/>	2	<input type="checkbox"/>		<input type="checkbox"/>	<input type="checkbox"/>
			C	<input checked="" type="checkbox"/>	3	<input type="checkbox"/>		<input type="checkbox"/>	<input type="checkbox"/>
			D	<input type="checkbox"/>	4	<input type="checkbox"/>		<input type="checkbox"/>	<input type="checkbox"/>
			E	<input type="checkbox"/>	5	<input type="checkbox"/>		<input type="checkbox"/>	<input type="checkbox"/>

**Cutting, Stabbing, Puncturing:**

<p>Can anyone be cut, stabbed, or punctured by coming in contact with moving plant or parts, sharp or flying objects, work pieces ejected, work pieces disintegrated, or other factors not mentioned?</p> <p><b>If persons are working in the vicinity of the plant, they could be punctured by the plant or components on the plant attachment (e.g., bucket teeth).</b></p>	Yes	No	A	<input type="checkbox"/>	1	<input type="checkbox"/>	High Significant Medium Low	<input type="checkbox"/>	
	<input checked="" type="checkbox"/>	<input type="checkbox"/>	B	<input type="checkbox"/>	2	<input type="checkbox"/>		<input type="checkbox"/>	<input checked="" type="checkbox"/>
			C	<input checked="" type="checkbox"/>	3	<input type="checkbox"/>		<input checked="" type="checkbox"/>	<input type="checkbox"/>
			D	<input type="checkbox"/>	4	<input type="checkbox"/>		<input type="checkbox"/>	<input type="checkbox"/>
			E	<input type="checkbox"/>	5	<input type="checkbox"/>		<input type="checkbox"/>	<input type="checkbox"/>

**Striking:**

<p>Can anyone be struck by moving objects due to plant or work pieces being ejected or disintegrated, mobility, uncontrolled or unexpected movement of the plant or other factors?</p> <p><b>If persons are in the vicinity of the working plant and plant attachment, they could be struck by the plant or plant attachment.</b></p>	Yes	No	A	<input type="checkbox"/>	1	<input checked="" type="checkbox"/>	High Significant Medium Low	<input checked="" type="checkbox"/>	
	<input checked="" type="checkbox"/>	<input type="checkbox"/>	B	<input type="checkbox"/>	2	<input type="checkbox"/>		<input type="checkbox"/>	<input type="checkbox"/>
			C	<input checked="" type="checkbox"/>	3	<input type="checkbox"/>		<input type="checkbox"/>	<input type="checkbox"/>
			D	<input type="checkbox"/>	4	<input type="checkbox"/>		<input type="checkbox"/>	<input type="checkbox"/>
			E	<input type="checkbox"/>	5	<input type="checkbox"/>		<input type="checkbox"/>	<input type="checkbox"/>

### Slipping, Tripping, Falling:

<p>Can anyone using the plant or in the vicinity of the plant, slip, trip or fall due to the working environment or other factors? poor housekeeping, dust on the floor around machines, slippery or uneven work surfaces or lack of guardrails.</p> <p><b>Depending on the operating location, the working environment could cause a person to slip trip or fall. Persons standing on the plant or plant attachment could slip and/or fall from it.</b></p>	Yes	No	A	<input type="checkbox"/>	1	<input type="checkbox"/>	High Significant Medium Low	<input type="checkbox"/>
	<input checked="" type="checkbox"/>	<input type="checkbox"/>	B	<input type="checkbox"/>	2	<input type="checkbox"/>		<input type="checkbox"/>
			C	<input checked="" type="checkbox"/>	3	<input type="checkbox"/>		<input type="checkbox"/>
			D	<input type="checkbox"/>	4	<input checked="" type="checkbox"/>		<input type="checkbox"/>
			E	<input type="checkbox"/>	5	<input type="checkbox"/>		<input type="checkbox"/>

### Shearing:

<p>Can anyone's body parts be cut off between two parts of the plant, or between a part of the plant and a work piece or structure? For example, on a metal guillotine can a finger fit under the guard.</p> <p><b>Persons not following SOP's or plant guidelines could become injured from misuse or working in the vicinity of the plant and plant attachment.</b></p>	Yes	No	A	<input type="checkbox"/>	1	<input checked="" type="checkbox"/>	High Significant Medium Low	<input type="checkbox"/>
	<input checked="" type="checkbox"/>	<input type="checkbox"/>	B	<input type="checkbox"/>	2	<input type="checkbox"/>		<input type="checkbox"/>
			C	<input type="checkbox"/>	3	<input type="checkbox"/>		<input type="checkbox"/>
			D	<input checked="" type="checkbox"/>	4	<input type="checkbox"/>		<input type="checkbox"/>
			E	<input type="checkbox"/>	5	<input type="checkbox"/>		<input type="checkbox"/>

### Friction:

<p>Can anyone be burnt due to contact with moving parts or surfaces of the plant, or material handled by the plant? For example, on the grinder is there more than 1 mm gap between the tool rest and the wheel?</p>	Yes	No	A	<input type="checkbox"/>	1	<input type="checkbox"/>	High Significant Medium Low	<input type="checkbox"/>
	<input type="checkbox"/>	<input checked="" type="checkbox"/>	B	<input type="checkbox"/>	2	<input type="checkbox"/>		<input type="checkbox"/>
			C	<input type="checkbox"/>	3	<input type="checkbox"/>		<input type="checkbox"/>
			D	<input type="checkbox"/>	4	<input type="checkbox"/>		<input type="checkbox"/>
			E	<input type="checkbox"/>	5	<input type="checkbox"/>		<input type="checkbox"/>

### High Pressure Fluid:

<p>Can anyone come into contact with fluids under high pressure, due to plant failure or misuse of the plant?</p> <p><b>The plant attachment utilizes the plants high pressure hydraulic system, if a failure occurs it is possible to come into contact with high pressure fluid.</b></p>	Yes	No	A	<input type="checkbox"/>	1	<input type="checkbox"/>	High Significant Medium Low	<input type="checkbox"/>
	<input checked="" type="checkbox"/>	<input type="checkbox"/>	B	<input type="checkbox"/>	2	<input checked="" type="checkbox"/>		<input type="checkbox"/>
			C	<input type="checkbox"/>	3	<input type="checkbox"/>		<input type="checkbox"/>
			D	<input checked="" type="checkbox"/>	4	<input type="checkbox"/>		<input type="checkbox"/>
			E	<input type="checkbox"/>	5	<input type="checkbox"/>		<input type="checkbox"/>

### Electrical:

<p>Can anyone be injured by electrical shock or burnt due to damaged or poorly maintained leads or switches, water near electrical equipment, working near or contact with live electrical conductors, lack of isolation procedures or the factors not mentioned? For example, are any switches broken, is there a red emergency stop? Can each machine be locked off for repairs?</p>	Yes	No	A	<input type="checkbox"/>	1	<input type="checkbox"/>	High Significant Medium Low	<input type="checkbox"/>
	<input type="checkbox"/>	<input checked="" type="checkbox"/>	B	<input type="checkbox"/>	2	<input type="checkbox"/>		<input type="checkbox"/>
			C	<input type="checkbox"/>	3	<input type="checkbox"/>		<input type="checkbox"/>
			D	<input type="checkbox"/>	4	<input type="checkbox"/>		<input type="checkbox"/>
			E	<input type="checkbox"/>	5	<input type="checkbox"/>		<input type="checkbox"/>

**Dust:**

<p>Can anyone suffer ill health or injury due to exposure to dust?                  For example, cutting, living silica                  Lack of vision – External influences causing the dust.                  Plant operation causing the dust.</p> <p><b>Depending on the operation location of the plant and plant attachment nuisance dust could become a factor.</b></p>	Yes	No	A	<input type="checkbox"/>	1	<input type="checkbox"/>	High Significant Medium Low	<input type="checkbox"/>
	<input checked="" type="checkbox"/>	<input type="checkbox"/>	B	<input type="checkbox"/>	2	<input type="checkbox"/>		<input type="checkbox"/>
			C	<input checked="" type="checkbox"/>	3	<input type="checkbox"/>		<input checked="" type="checkbox"/>
			D	<input type="checkbox"/>	4	<input checked="" type="checkbox"/>		<input type="checkbox"/>
			E	<input type="checkbox"/>	5	<input type="checkbox"/>		<input type="checkbox"/>

**Noise:**

<p>Can anyone suffer hearing discomforts while the plant is in use? For example, the plant is noisy, and it is difficult to hear.</p> <p><b>Hearing discomfort may be experienced by persons due to the noise generated by the plant. This can also lead to miscommunication.</b></p>	Yes	No	A	<input type="checkbox"/>	1	<input type="checkbox"/>	High Significant Medium Low	<input type="checkbox"/>
	<input checked="" type="checkbox"/>	<input type="checkbox"/>	B	<input type="checkbox"/>	2	<input type="checkbox"/>		<input type="checkbox"/>
			C	<input checked="" type="checkbox"/>	3	<input checked="" type="checkbox"/>		<input checked="" type="checkbox"/>
			D	<input type="checkbox"/>	4	<input type="checkbox"/>		<input type="checkbox"/>
			E	<input type="checkbox"/>	5	<input type="checkbox"/>		<input type="checkbox"/>

**Vibration:**

<p>Can anyone suffer injury due to the vibration of the plant?</p>	Yes	No	A	<input type="checkbox"/>	1	<input type="checkbox"/>	High Significant Medium Low	<input type="checkbox"/>
	<input type="checkbox"/>	<input checked="" type="checkbox"/>	B	<input type="checkbox"/>	2	<input type="checkbox"/>		<input type="checkbox"/>
			C	<input type="checkbox"/>	3	<input type="checkbox"/>		<input type="checkbox"/>
			D	<input type="checkbox"/>	4	<input type="checkbox"/>		<input type="checkbox"/>
			E	<input type="checkbox"/>	5	<input type="checkbox"/>		<input type="checkbox"/>

**Environmental:**

<p>Can the plant operation cause an environmental issue? For example – pollution, waste materials, noise.</p>	Yes	No	A	<input type="checkbox"/>	1	<input type="checkbox"/>	High Significant Medium Low	<input type="checkbox"/>
	<input type="checkbox"/>	<input checked="" type="checkbox"/>	B	<input type="checkbox"/>	2	<input type="checkbox"/>		<input type="checkbox"/>
			C	<input type="checkbox"/>	3	<input type="checkbox"/>		<input type="checkbox"/>
			D	<input type="checkbox"/>	4	<input type="checkbox"/>		<input type="checkbox"/>
			E	<input type="checkbox"/>	5	<input type="checkbox"/>		<input type="checkbox"/>

**Risk Evaluation**

Overall risk category of plant:	High	Significant	Medium	Low
---------------------------------	------	-------------	--------	-----

**Risk Controls**

Most Desirable

- |          |  |   |
|----------|--|---|
| <p>↓</p> | <ul style="list-style-type: none"> <li>• Elimination</li> <li>• Substitution</li> <li>• Engineering Controls</li> <li>• Isolation</li> <li>• Administrative Controls</li> <li>• PPE</li> </ul> | <ul style="list-style-type: none"> <li>- The best way to eliminate the risk is to remove the hazard.</li> <li>- Substitute the hazardous plant with a safer part, alternative process.</li> <li>- Design modification, installation of guarding, automation/ventilation.</li> <li>- Isolate the plant, barricades, crossing, bunting, etc.</li> <li>- Permits, clearances, lock out systems, certification.</li> <li>- Short term control measure.</li> </ul> |
|----------|--|---|

Least Desirable

Hazard	Controls
Entanglement	<p>Isolation – Ensure the operating and maintenance manual provided with the plant attachment recommends the operator of the plant always follows SOP. The operator must make everybody working in the vicinity of the attachment aware of the dangers and only operate if people are a safe distance away.</p> <p>PPE – Ensuring all people who will be in the vicinity of the plant attachment during operation be wearing clothes that mitigate the chances of becoming entangled by accident.</p>
Crushing, Striking	<p>Isolation – Ensure the operating and maintenance manual provided with the plant attachment recommends the operator of the plant always follows SOP. The operator must make everybody working in the vicinity of the attachment aware of the dangers and only operate if people are a safe distance away.</p> <p>PPE – The use of the correct PPE for the worksite will minimize the damage caused by an incident. A hard hat, steel cap boots and tough worksite clothes as an example.</p> <p>PPE – The use of high visibility PPE will help reduce the case of incidents occurring from impaired vision or operator distraction.</p>
Cutting, Stabbing, Puncturing	<p>Isolation – Ensure the operating and maintenance manual provided with the plant attachment recommends the operator of the plant always follows SOP. The operator must make everybody working in the vicinity of the attachment aware of the dangers and before moving the plant ensure people are a safe distance away.</p> <p>PPE – The use of the correct PPE for the worksite will minimize the risk of cutting when working in and around the attachment. Gloves and tough work clothes will reduce the risk associated with touching or bumping into sharp edges on the attachment whilst it is not in operation.</p>
Slipping, Tripping, Falling	<p>Engineering Controls – A textured foot plate has been added to the design to help getting into and out of the plant.</p> <p>Isolation – The plant attachment has NOT been designed to stand on unless entering or exiting the plant. This will be stated in the operating and maintenance manual. It is the responsibility of the operator to ensure that no persons stand on the plant attachment.</p> <p>PPE – Wearing the correct work boots will reduce chances of slipping.</p>

<p>Shearing</p>	<p>Isolation – Ensure the operating and maintenance manual provided with the plant attachment recommends the operator of the plant always follows SOP. The operator must make everybody working in the vicinity of the attachment aware of the dangers and before moving the plant ensure people are safe distance away.</p> <p>Administrative Controls – A warning sticker should be placed in visible position on the plant attachment highlighting the potential risk.</p>
<p>High Pressure Fluid</p>	<p>Engineering Controls – The routing of the hydraulic hoses and the design of the plates which guard the hydraulic motor minimize the risk of the hydraulic failure and exposure to high pressure fluids.</p> <p>Administrative Controls – The manual will address correct maintenance schedules for the plant attachment hydraulics to reduce the risk associated with hydraulic component failure.</p> <p>Administrative Controls – A warning sticker should be placed in a visible position on the plant attachment highlighting the potential risk.</p>
<p>Dust</p>	<p>Isolation and Administrative Controls – To reduce the hazards associated with dust, the manual should instruct the operator to consider their working environment and operate in a manner to reduce the risk of dust being kicked up. This can be managed by operating at a sensible speed.</p> <p>PPE – If the environment is such that the dust cannot be sufficiently controlled, the onsite supervisor should ensure all workers are wearing the correct PPE.</p>
<p>Noise</p>	<p>PPE – The plant attachment should not generate excessive noise, however the work environment it is being used in might cause hearing discomfort. The operator and site supervisor should ensure all workers always have the correct hearing protection.</p>

### **Any Modification to Plant Attachment Voids Risk Assessment**

**Purchaser and User are required to conduct their own risk assessment to identify hazards prior to use.**

This risk assessment does not necessarily cover all possible hazards associated with this product and should be utilized in conjunction with the purchasers and users individual risk assessments to identify all environmental, health, and safety risks associated with specific tasks, locations, and personnel.



# 10 PARTS

## QUALITY BACKUP

*We manufacture 90% of our parts inhouse.  
This means we can get your parts to you... quickly.*

### 10.1 ORDERING PARTS

For ordering parts contact either your dealer or Norm Engineering directly. Contact details are included at the front of this manual. To assist, note the details of your 4in1 loader style bucket in the spaces provided under *Section 10.1.1 Reference Information.*

#### 10.1.1 REFERENCE INFORMATION

Always refer to the model and serial number when ordering parts or requesting from you dealer. The serial number for this product is located on the identification place of your 4in1 loader style bucket.

Model Number:

.....

Make:

.....

Serial Number:

.....

Date Purchased:

.....

# 11 PARTS LIST

## STANDARD PARTS LIST

Item	QTY	Description	Refer to Diagram
1	2	Cast arm	1
2	1	2.5" Bore – 8" Stroke – L.H. Hydraulic Cylinder	1, 3
3	1	2.5" Bore – 8" Stroke – R.H. Hydraulic Cylinder	1, 3
4	2	Hydraulic cylinder top pin & flag	1
5	2	Hydraulic cylinder bottom pin	1
6	2	Pivot pin	1
7	2	Pivot bush	1

Diagram 1

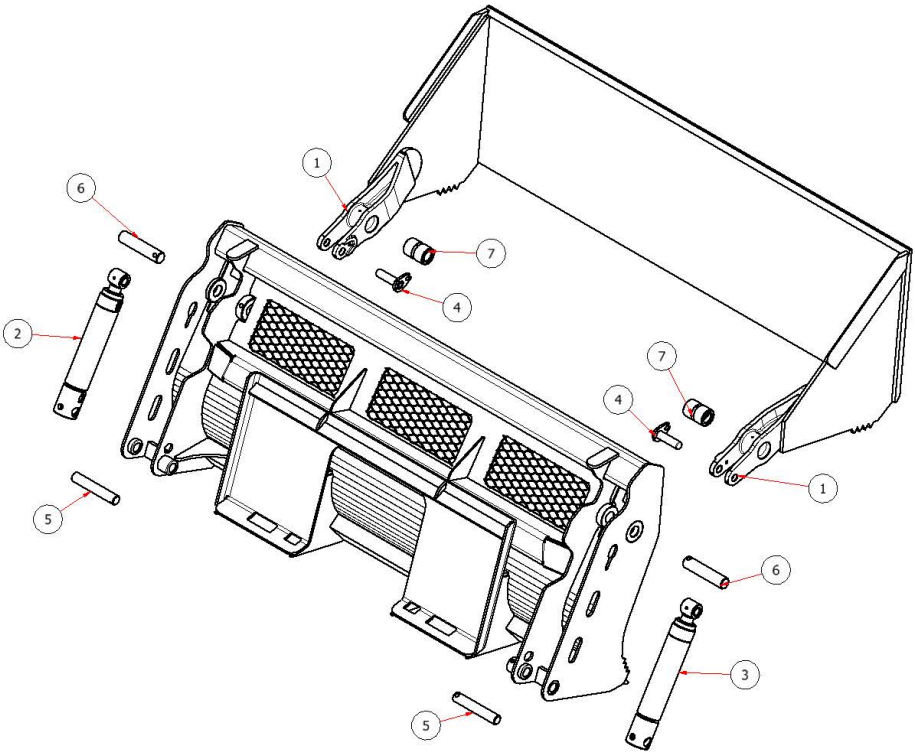

## OPTIONAL PARTS LIST

Item	QTY	Description	Refer to Diagram
8	1	Bolt-on cutting edge – rear	2
9	1	Bolt-on cutting edge – middle	2
10	1	Bolt-on cutting edge – front	2

Diagram 2

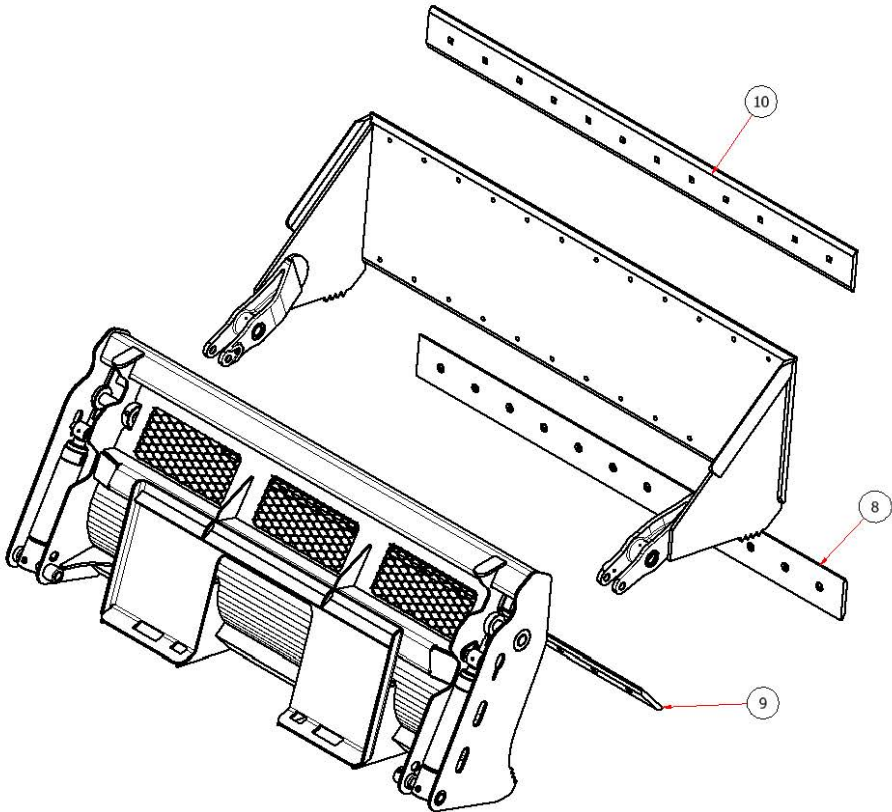

## CYLINDER PARTS LIST

Item	QTY	Description	Refer to Diagram
3-1	1	Barrel	3
3-2	1	End cap, port inline	3
3-3	1	Gland	3
3-4	1	Rod weldment	3
3-5	1	Piston	3
3-6	1	Piston retaining nut	3
3-7	2	Hardened bush	3
3-8	1	Seal kit	3
3-9	2	Grease nipple	3

**Diagram 3**

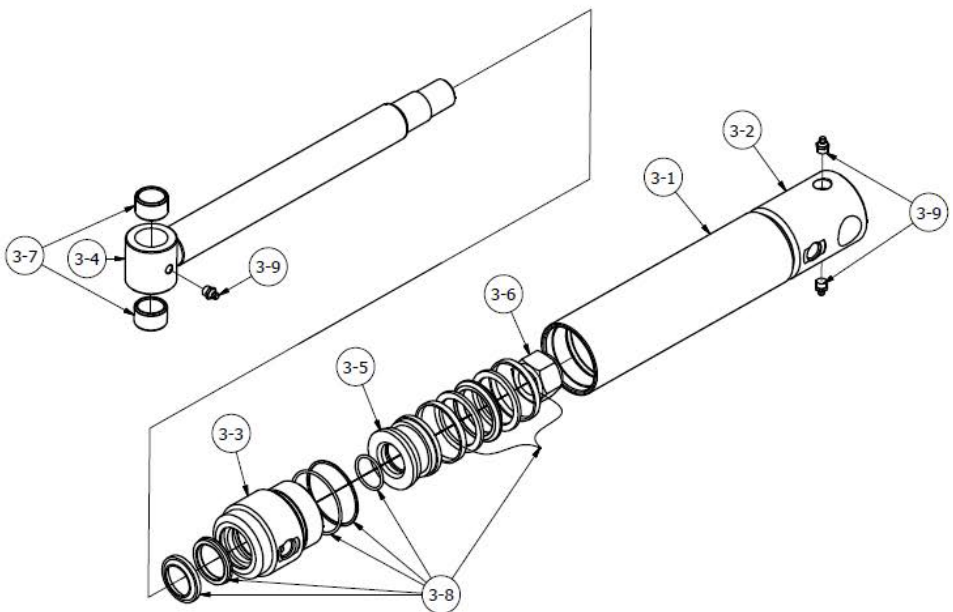

# 12 APPENDICES

## 12.1 SAFETY SIGN LOCATIONS

Item	Description
1	Warning   Pinch point
2	Danger   High pressure fluid
3	Warning   Attachment can contact machine
4	Danger   Read the manual



ITEM 1



ITEM 2



ITEM 3



ITEM 4

### Instructions

- Keep all safety signs clear and legible.
- Replace all missing, illegible, or damaged safety signs.
- When replacing parts which have safety signs attached make sure the replacement part has the safety sign.

# A.2 MAINTENANCE SCHEDULE SAMPLE

<b>Section 1    Prior to use checks</b> <i>Recommended checks described in Section 7.2</i>				
Date	Time	Operator Safety Checks (name of operator or competent person)	Name of company	Signature
	am/pm			
	am/pm			
	am/pm			
	am/pm			
	am/pm			
	am/pm			
	am/pm			
	am/pm			
	am/pm			
	am/pm			
	am/pm			
	am/pm			
	am/pm			
	am/pm			
	am/pm			
	am/pm			
	am/pm			
	am/pm			

**Section 2 || Weekly and routine maintenance and safety checks***Recommended checks described in Section 7.3*

Date	Hour meter	Name of inspector	Company	Qualifications	Signature
	h				
	h				
	h				
	h				
	h				
	h				

**Section 3 || Faults, difficulties, and problems log***Record all issues that are discovered during any of the recommended maintenance checks.*

Date	Time	Fault, difficulty, or problem	Company	Repairs	
				Comment	Signature
	am/pm				
	am/pm				
	am/pm				
	am/pm				
	am/pm				
	am/pm				

# 13 WARRANTY

## 13.1 DEFINITION

**“Dealer”** means a dealer that purchases products directly from Norm Engineering Pty Ltd.

**“End consumer”** means a consumer that purchases products either directly from Norm Engineering Pty Ltd or directly from a “dealer” as defined above.

**“Products”** includes goods and services.

## 13.2 WARRANTY

Norm Engineering Pty Ltd welcomes you as a purchaser of its products. All Norm Engineering products are designed to ensure the highest standards, reliability, and performance.

Norm Engineering Pty Ltd warrants hydraulic cylinders against defects in manufacture for a period of twelve months from date of sale by the dealer or Norm Engineering Pty Ltd to the end consumer. The warranty in relation to hydraulic cylinders ceases upon the occurrence of damage to the piston rod of the hydraulic cylinder.

No warranty applies to hoses, tubes, and fittings in relation to any of the products.

Norm Engineering Pty Ltd warrants all its other products against defects in manufacture for a period of twelve months from the date of sale by the dealer or Norm Engineering Pty Ltd to the end consumer.

Norm Engineering Pty Ltd will, subject to the terms of this warranty, in relation to defective goods:

- a) replace the defective goods at no cost to the end consumer; or
- b) repair the defective goods at no cost to the end consumer; or
- c) pay the cost of having the defective goods repaired.



Norm Engineering Pty Ltd will, subject to the terms of this warranty, in relation to defective services:

- a) supply the services again to the end consumer at no cost to the end consumer; or
- b) pay the cost of having the service supplied again to the end consumer.

Warranty claims may be sent either to Norm Engineering Pty Ltd., P.O. Box 178, Mt Ommaney, Qld. 4074 or to the dealer.

All warranty periods shall commence from the date of sale by Norm Engineering Pty Ltd or the dealer to the end consumer. It is the end consumer's responsibility to establish the date of sale of the product to the end consumer by the dealer.

The end consumer may establish the date of sale by producing to Norm Engineering Pty Ltd the dated contract of sale between the end consumer and the dealer with its warranty claim.

If the end consumer is not able to establish the date of sale of the product to the end consumer by the date of its warranty claim, the warranty period shall be deemed to commence from the date of sale of the product by Norm Engineering Pty Ltd to the dealer.

This warranty will not apply if the end consumer does not use the product in accordance with Norm Engineering Pty Ltd's recommendation.

This warranty will not apply if the end consumer does not use products applied or fitted to any machine, equipment, or plant, in accordance with Norm Engineering Pty Ltd's operating recommendation for the product.

This warranty does not apply to any loss or damage caused through consequential neglect. Unless the end consumer indicates to Norm Engineering Pty Ltd prior to purchasing the product that it intends to use the product for a particular purpose, there is no implied warranty that the product will fit for that particular purpose. Ask Norm Engineering for clarification of the intended use is not included in the manual.

Only a dealer authorised in writing, or issued with an order number, by Norm Engineering Pty Ltd may carry out warranty repairs. Prior written approval must be obtained from Norm Engineering Pty Ltd before warranty repairs are carried out. Norm Engineering Pty Ltd will not recognise any warranty claim for reimbursement of repair costs unless the repairs have been carried out by an authorised dealer with prior written approval from Norm Engineering Pty Ltd to carry out the repairs.

Norm Engineering Pty Ltd limits its liability, as follows:

1) Pursuant to Section 68A of the Trade Practices Act 1974, this clause applies in respect of any of the goods or services supplied under this contract which are not of a kind ordinarily acquired for personal, domestic, or household use or consumption, provided that this clause will not apply if the end consumer establishes that reliance on it would not be fair and reasonable.

2) Liability for breach of a condition or warranty implied into this contract by the Trade Practices Act 1974 other than a condition implied by Section 69 is limited:

a) In the case of goods, to any one of the following as determined by Norm Engineering Pty Ltd:

i. the replacement of goods

ii. the repair of the goods

iii. the payment of the cost of having the goods repaired, excluding travelling and freight charges.

b) In the case of services, to any one of the following as determined by Norm Engineering Pty Ltd.

i. the supplying of the services again; or

ii. the payment of the cost of having the services supplied again

Expenses incurred by the end consumer in connection with making a warranty claim shall be borne by the end consumer unless otherwise agreed by Norm Engineering Pty Ltd.

To the extent permitted by law, all implied conditions, and warranties in the contract of sale between Norm Engineering Pty Ltd and the end consumer are hereby excluded.

The benefits conferred by this warranty on the end consumer are in addition to all other legal rights and remedies that the end consumer has in respect of the products.

Contracts of sale for products, and this warranty are submitted to the exclusive jurisdiction of the courts of Queensland.

Notes:

---

---

---

---

---

---

---

---

---

---

---

---

---

---

---

---

---

---

---

---

---

---

---



Notes:

---

---

---

---

---

---

---

---

---

---

---

---

---

---

---

---

---

---

---

---

---

---

---

---



# WARRANTY NOTICE

**DEALER:** .....

STATE: ..... SIGNED: .....

**END CONSUMER:**

NAME: .....

ADDRESS: .....

.....

.....

STATE: ..... POSTAL CODE: .....

PHONE: ..... SIGNED: .....

DATE OF SALE TO THE END CONSUMER: ...../...../.....

DESCRIPTION OF PRODUCTS: .....

.....

.....

.....

SERIAL NO: .....

DELIVERY DOCKET NO: .....

DELIVERY DATE: ...../...../.....

**NOTE: THIS FORM IS TO BE COMPLETED BY THE DEALER AND RETURNED TO: NORM ENGINEERING - P O BOX 178 MT OMMANEY, BRISBANE, QUEENSLAND, AUSTRALIA, 4074**