



# 4FT SLASHER

## OPERATING & MAINTENANCE MANUAL



SALES@NORMENG.COM.AU • 07 3376 3177 • WWW.NORMENG.COM.AU

### BRISBANE

PH: 07 3376 3177  
FAX: 07 3376 3201  
787 BOUNDARY ROAD  
DARRA QLD 4076

### MELBOURNE

PH: 03 9775 1965  
FAX: 03 9786 9102  
2/45 FRANKSTON GARDENS DRIVE  
CARRUM DOWNS VIC 3201

# Contents

1	Introduction .....	1
2	Safety Definitions: Terms and Symbols.....	2
3	Safety Instructions .....	3
3.1	Important Points .....	5
4	Predelivery .....	6
4.1	Check Pickup Fit .....	6
4.2	Check Range of Motion.....	6
4.3	Check Hydraulic Hoses .....	7
4.4	Hydraulic Motor Running-in.....	7
5	Assembly Instructions .....	8
5.1	Hitching Up the 4ft Slasher .....	8
5.2	Removing the 4ft Slasher.....	9
6	Operating Instructions.....	10
6.1	Starting the Slasher.....	10
6.2	Specified Operations and Limitations.....	10
6.3	Auxiliary Hydraulic Requirements .....	11
6.3.1	Connecting the Case Drain .....	11
6.4	Reasonably Foreseeable Misuse .....	12
6.5	Cutting Technique .....	12
7	Maintenance and Care.....	14
7.1	Hydraulics.....	14
7.2	Prior to Use .....	14
7.3	Routine Inspection (Every 12 Weeks).....	15
7.4	Gearbox Maintenance .....	15
7.5	Cutting System Maintenance .....	16
7.5.1	Blade Removal .....	16
7.6	Blade Installation.....	17
7.6.1	Blade Hub Disassembly .....	18

7.6.2	Blade Hub Assembly & Installation .....	19
8	Risk Assessment .....	20
9	Parts .....	27
9.1	Ordering Parts .....	27
9.1.1	Reference Information.....	27
10	Parts List .....	28
11	Appendices.....	39
11.1	Safety Sign Locations .....	39
12	Warranty .....	40
12.1	Definition .....	40
12.2	Warranty.....	40

# 1 INTRODUCTION



**4ft Slasher**

Congratulations on purchasing a Norm Engineering Pty Ltd attachment. We have designed this 4ft slasher for a long, productive, and safe life. Your attachment will provide you with years of service provided regular maintenance and correct usage is applied.



This manual offers a guide on how to safely assemble, mount, operate and maintain your 4ft slasher. While the manual attempts to cover most situations, there are many unforeseen risks and events that are not included due to the capability of the 4ft slasher. On this basis the owner and/or operator must determine if this attachment is suited for a particular purpose.

Norm Engineering Pty Ltd can accept no responsibility or liability for how you operate your equipment: we can only provide warning notes and safety precautions in relation to the standard operation of the 4ft slasher.

The illustrations and data used in this manual were current at the time of printing but due to possible engineering and/or production changes, this product may vary slightly. Norm Engineering Pty Ltd reserves the right to redesign and/or change components as may be necessary without notification.

## 2 SAFETY DEFINITIONS: TERMS AND SYMBOLS

We will use the ANSI Z535.4-2011(R2017) standard for the definitions of signal words as described in conjunction with colours red, orange, and yellow. These are used with the Safety Alert Symbol:

- **Signal word:** Are defined as the words used in the signal word panel. The signal words for hazard alerting signs are “DANGER”, “WARNING”, and “CAUTION”. Safety notice signs use the signal word “NOTICE”. Safety instruction signs use signal words that are specific to the situation.
- **DANGER:** Indicates a hazardous situation, which, if not avoided, **will** result in death or serious injury. This signal word is to be limited to the most extreme situations. (White letters on a red background) 
- **WARNING:** Indicates a hazardous situation, which, if not avoided, **could** result in death or serious injury. (Black letters on an orange background) 
- **CAUTION:** Indicates a hazardous situation, which, if not avoided, **could** result in minor or moderate injury. (Black letters on a yellow background) 
- **NOTICE:** Indicates information considered important, but **not** hazard-related (e.g., messages relating to property damage). (White letters on a blue background) 
- **SAFETY INSTRUCTIONS:** Indicates a type of safety sign, where specific **safety-related instructions** or **procedures** are described. More definitive signal words are encouraged, where practical (e.g., SAFE SHUTDOWN PROCEDURE, SAFE OPERATING PROCEDURE). (White letters on a green background) 

### 3 SAFETY INSTRUCTIONS



Obey all the safety instructions listed in this section and throughout this manual. Failure to follow instructions could result in death or serious injury.

#### NOTICE

Before attempting any type of assembly operation, maintenance, or other work on or near this product:

- READ and COMPLETELY UNDERSTAND:
  - This manual,
  - The manuals provided with the power unit being used with this attachment.
- Read and understand all safety signs associated with the equipment being used.
- Know all your controls and know how to quickly stop all power unit movement, the attachment movement, and the engine in case of an emergency.

**SAFETY IS YOUR RESPONSIBILITY AS THE OPERATOR OF THE EQUIPMENT**

Inappropriate and/or irresponsible use of a 4ft slasher may cause serious injury and trauma. The operator must have all relevant industry competencies, qualifications, certificates and/or licenses.

The operator must understand their responsibilities under the relevant acts and regulations of the governing body. Failure to comply with your legal obligations under the act may result in prosecutions against you.

As the equipment operator you are responsible to familiarise yourself, and anyone else who will assemble, operate, maintain, or work around this product with the safety information contained within this manual. You must make certain that all operators and maintenance personnel have a complete understanding of the full and exact contents of this manual and those of the power unit.

There are usually specific precautions and steps in the power unit operating manual to be taken to ensure your safety prior to engaging the attachment.

Conduct a job site survey during the planning phase of any construction project to identify potential hazards and develop and implement appropriate control measures to protect workers.

Accidents are preventable if the equipment operator is careful and responsible. No accident prevention program can be successful unless there is a wholehearted commitment and cooperation of the person who is directly responsible for the operation of the equipment.

Make sure anyone who will be installing, maintaining, repairing, removing, and/or storing this product applies the Workplace Health and Safety Act requirements. This includes ensuring that the person has been instructed in the safe operation of this product and of the power unit to which this attachment is likely to be attached.

Know and follow good work practices, some of these include:

- To optimise the physical environment such as having a well-lit, level surface that is clean and dry to work on.
- Use properly grounded, test and tagged electrical outlets and tools.
- Use the right tool for the job at hand.
- Make sure that your tools are in good condition for performing the required function.
- When using tools, wear the protective equipment specified by the tool manufacturer (hardhat, safety glasses, work gloves, protective shoe...)
- When the attachment has been out in the sun, remember to wear protective gloves as the metal will be hot to touch.
- Before starting, know the job duration, job complexity, and best procedure.
- Ensure workers have the capacity to do the job.
- Check that all hazards have been identified and control measures implemented.
- Clear communication so everyone present knows what is happening.
- Clear emergency stop procedure so there is no confusion in an emergency.
- Ensure the use of tyre stoppers and securing framework to stop the plant and plant attachment moving during maintenance.

## 3.1 IMPORTANT POINTS

When your power unit is used during any type of assembly, operation, maintenance, or other work on or near this product:

- Before leaving the operator's station or before beginning any type of work on this product, lower this product to the ground, apply your power unit's parking brake, stop the engine, remove the starter key, wait for all moving parts to stop and then relieve all pressure in the hydraulic lines. Refer to your power unit's operating manual for instructions on preparing the equipment for hitching up an attachment and relieving hydraulic pressure in lines.
- Know your power unit's safe lifting and operating capacity and the weight of this product. (Check the parent machines operator manuals for safe operating limits).
- Only allow the operator to be around the power unit or this product when either is in motion. Ensure work area is clear of all personnel.
- Apply all safety guidelines in relation to the operator and the equipment.
- Only operate controls from the operator's station.
- Maintain operator presence at all times when the engine is running, or the product is raised on the power unit.
- Reduce speeds when additional weight and width need to be considered especially over rough ground.
- Consider the operating environment if dust is a concern reduce the machine speed.
- Whilst in motion keep the product close to the ground and under control.



## 4 PREDELIVERY

The following steps should be performed when fitting this attachment to a power unit for the first time. Failure to perform these checks may lead to damage of the attachment, the power unit and be a risk to safety. Warranty claims that arise as a result of skipping these steps may be challenged.

### 4.1 CHECK PICKUP FIT

Perform '5.1 Hitching Up the 4ft Slasher' to check how the attachment fits the coupler. Check for the following:

- Do the pins lock?
- Is it a snug fit?

### 4.2 CHECK RANGE OF MOTION

Carefully go through all safe range of motions for the parent machine. If unexpected contact occurs, contact Norm Engineering to discuss. Due to the capabilities of this product some contact with the machine may be unavoidable. In this case place the warning sticker provided on the attachment and inform the owner/operator.



## 4.3 CHECK HYDRAULIC HOSES

If you are unsure how to route the hydraulic hoses, contact Norm Engineering. Connect hoses and once again thoroughly check full range of motion to make sure:

- They do not pull tight.
- They do not have excessive length.

If the hose length is not correct, call Norm Engineering first for assistance.

## 4.4 HYDRAULIC MOTOR RUNNING-IN

To maximise the life of the unit, it must be run in for a period. To carry out the running in procedure, suspend the slasher just off the ground in a horizontal working position. Ensure there are no bystanders within the nominated radius as defined in the risk assessment completed prior to commencing any works.

Operate the motor at 30% of rated pressure for 20 minutes before application of full operating load.

## 5 ASSEMBLY INSTRUCTIONS



Obey all instructions listed in this section of the manual. Failure to follow the instructions listed below could lead to serious injuries.

For any assistance with the following processes, please contact Norm Engineering.

### 5.1 HITCHING UP THE 4FT SLASHER



All safety precautions pertaining to both the power unit and the 4ft slasher need to be

followed. Sufficient planning should be made prior to any work commencing in case of an emergency situation.

**Step one:** Before beginning any work on this product, lower the product to the ground on a firm level surface that is large enough to accommodate this product, the power unit and all workers involved in the hitching up the 4ft slasher.

**Step two:** Refer to your power unit's operating manual for instructions on hitching up this attachment. Visually inspect to ensure the attachment is fully engaged to the power unit hitch.

**Step three:** Engage the locking mechanism. A visual inspection should be performed to confirm all locking systems are secured. Give the 4ft slasher a few short sharp movements close to the ground to ensure it is engaged.

**Step four:** Rest the attachment on the ground and refer to the power unit operating manual to release the pressure in the hydraulic system.

**Step five:** Connect the hydraulic couplings on the 4ft slasher to the power unit couplings following all safety precautions specified in the power units operating manual.

**Step six:** Start the machine and cycle the 4ft slasher hydraulic motor several times before taking it near other personnel.

## 5.2 REMOVING THE 4FT SLASHER



All safety precautions pertaining to both the power unit and the 4ft slasher need to be followed. Sufficient planning should be made prior to any work commencing in case of an emergency situation.

**Step one:** Remove the machine from anywhere near other personnel and onto a firm level surface large enough to safely accommodate this product, the power unit and all workers involved in removing the 4ft slasher.

**Step two:** Rest the 4ft slasher on the ground.

**Step three:** Disconnect the attachments hydraulic couplings from the power unit following all safety precautions. Refer to your power unit's operating manuals.

**Step four:** Disengage the locking mechanism. A visual inspection should be performed to make sure the 4ft slasher is fully disengaged.

**Step five:** Refer to your power unit's operating manual for instructions on removing the attachment and confirm the hitch is fully disengaged from the 4ft slasher.

**Step six:** Store safely.

## 6 OPERATING INSTRUCTIONS



### DANGER

When using the 4ft slasher, ensure all personnel wear appropriate personal protective equipment at all times. All personnel must stand well clear of the 4ft slasher during operation. Contact with the attachment, parent machine or flying debris and dust could cause injury to personnel working in the vicinity of the machine.



### WARNING

- **USED** for slashing grass **ONLY** and not for any other purposes.

- **REFER** to the parent equipment (power unit) manual to ensure you follow all the limits specified. i.e. load limits.



### CAUTION

- **ENSURE** the skids of the slasher are in contact with the ground at **ALL** times when the blades of the slasher are in motion.

- **ENSURE** that all safety chains and guards are intact and undamaged.
- **ENSURE** that the slasher is only ever used for its intended purpose, it is not designed to carry any load whatsoever.

### 6.1 STARTING THE SLASHER

#### NOTICE

**ALWAYS** engage the slasher with the engine at idle and then gradually increase the revs until you reach operating speed.

Starting the slasher with the high engine revs may cause damage to the slasher's drive train and will lead to premature failure.

### 6.2 SPECIFIED OPERATIONS AND LIMITATIONS



### DANGER

The 4ft slasher is **NOT** to be used:

- to carry people;
- as a lifting point;
- to pull or push over objects;
- to trim hedges or bushes.

Misuse may damage the attachment or lead to injury and trauma.

## 6.3 AUXILIARY HYDRAULIC REQUIREMENTS



Exceeding the hydraulic flow rates and pressures provided below **WILL** cause damage to your slasher and **MAY** cause

injury and/or death. This damage is not covered by the warranty provided with your slasher.

### NOTICE

If your machine is not capable of producing the flow rates and pressures provided below the slasher will not cut the grass cleanly.

<b>Motor</b>			
<b>Gearbox</b>			
<b>Minimum Pressure [PSI]</b>		<b>Maximum Pressure [PSI]</b>	
<b>Minimum Flow [LPM]</b>		<b>Maximum Flow [LPM]</b>	

### 6.3.1 CONNECTING THE CASE DRAIN

If your machine has a case drain breakaway line installed, it is recommended you connect the case drain coupling – even if the auxiliary flow is less than those stated in the table below.

If your machine **DOESN'T** have a case drain breakaway port the slasher can be used as long as the flow remains below the figures listed in the table below.

<b>Motor Model</b>	<b>Auxiliary flow [LPM] (If flow exceeds this value, case drain is mandatory)</b>
80CC [B8704]	40
100CC [B8705]	50
160CC [B8706]	60
200CC [B8710]	70

## 6.4 REASONABLY FORSEEABLE MISUSE



**DANGER**

Misuse of the slasher significantly increases the risks involved in the operation. It is the responsibility of the operator to ensure the activity they are undertaking is safe, not only for themselves but for other persons in the area.

Misuse of the slasher will invalidate the warranty offered by Norm Engineering. Cost of repairs will be the sole responsibility of the equipment owner.

Reasonably foreseeable misuses include but are not limited to:

- **OPERATING** the slasher off the ground.
- **OPERATING** the slasher at an angle to the ground. For example, never roll the slasher back during operation. The slasher skids should always remain in contact with the ground.
- **USING** the slasher to cut vegetation other than grass. This **WILL** cause damage to the slasher and **COULD** cause an injury or fatality.



**DANGER**

- **OPERATING** the slasher **WITHOUT** performing section "7.2 Prior to Use".

## 6.5 CUTTING TECHNIQUE

During operation, the slasher skids should be kept parallel and in close proximity to the ground at all times. To extend the life of the slasher body, the slasher should be operated with minimal pressure between the skids and the ground. To assist with keeping the pressure off the skids, the 4ft slasher has the option of fitting a wheel kit. The central wheel at the front of the attachment helps maintain the skids close proximity with the ground without digging in. This operating technique will reduce the wear in skids and should provide a better finish.



As the slasher is a hydraulically powered implement, the performance of the slasher depends on the available hydraulic power of the parent machine. If the cutting conditions are extremely tough and the slasher is struggling to cut the grass cleanly, it is recommended to take a narrower cut. This will require less power and create space for the cut grass to clear itself out the rear of the slasher.

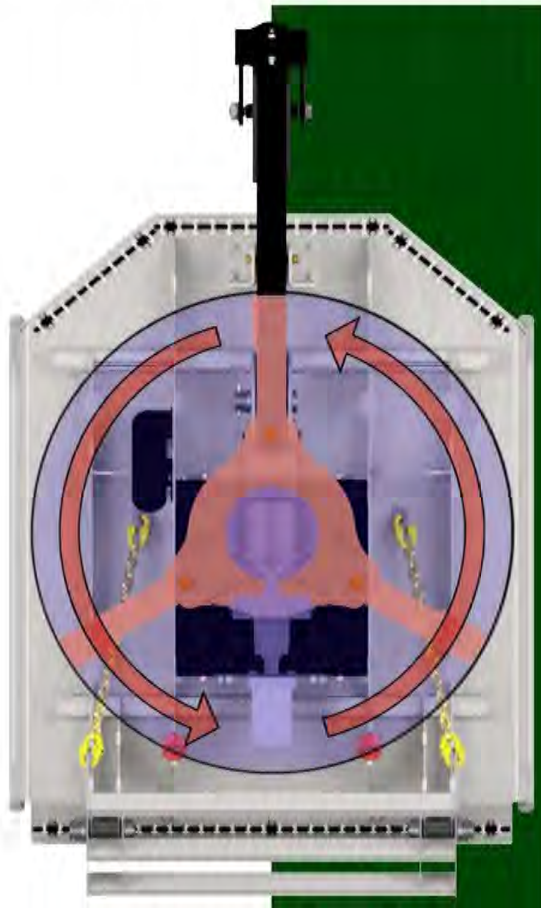

The slasher rotates anti-clockwise (looking from above) and so material will discharge out the left hand rear corner of the slasher. To maximise performance, when taking a partial cut, ensure the uncut grass is on the right hand side of the slasher.



## 7 MAINTENANCE AND CARE

### **WARNING**

**BEFORE** commencing maintenance, place the attachment on level ground. Ensure enough area to perform maintenance on the attachment. Follow 5.2 Removing the 4FT Slasher.

### **WARNING**

**AFTER** maintenance is complete, follow 5.1 Hitching Up the 4FT Slasher.

### 7.1 HYDRAULICS

#### **WARNING**

Read and understand all safety requirements prior to beginning any

maintenance to any hydraulic connections. It is imperative that if there are any fittings, repairs etc. required these must be conducted by a fully certified and qualified hydraulics fitter.

### 7.2 PRIOR TO USE

Prior to use, the 4ft slasher shall be visually inspected to verify the attachment is in an operational state. The inspection will check for:

- Signs of wear, including corrosive and abrasive wear.
- Markings are legible.
- Welds are not damaged, cracked or worn,
- Hydraulic hoses, fittings, gearbox, clutch, and motor are in good condition with no leaks.
- All fasteners are in place and correctly torqued.

#### **DANGER**

Pay particular attention to the bolts that secure the blades. These must be correctly torqued and undamaged to ensure safe operation of the slasher.

- Inspect the wear on the skids.
- Grease all fittings – this needs to be performed on a daily basis. **DON'T** grease the one-way clutch (it is a sealed unit).

#### **DANGER**

If the slasher **DOES NOT** pass any of the above checks **DO NOT** operate the slasher until they are remedied.

## 7.3 ROUTINE INSPECTION (EVERY 12 WEEKS)

Routine inspections should include but is not limited to the following:

- Fittings, hoses, and hydraulics must be checked to ensure there are no leaks.
- Pins and bushes should be inspected for signs of excessive wear and replaced before the wear damages the structure of the 4ft slasher.
- Inspect the attachment for wear, particularly around the skids, blades, and seek advice on repairs if wear is excessive.
- Check to ensure attachment markings are legible.
- Organise for a certified and qualified hydraulics fitter to inspect and replace hydraulic hoses and seals in the hydraulic parts, as necessary. For additional information refer to section '12 Warranty'.

## 7.4 GEARBOX MAINTENANCE

The gearbox oil should be changed after the first 50 hours of use and every 300 hours thereafter. If the slasher is not used on a regular basis, the oil should be changed at least once every 12 months.

The oil used in the gearbox should be SAE 80W-90 gear oil.

A suction gun will be required to remove the old oil from the gearbox whenever an oil change is performed.

## 7.5 CUTTING SYSTEM MAINTENANCE



- **DO NOT** use blocking material that could collapse or shift positions.
- **DO NOT** use wood or steel blocking that shows any signs of material decay.
- **DO NOT** use blocking that is warped, twisted, or tapered.
- **ENSURE** a safe working environment prior to replacing any slasher component.
- **USE** new fasteners whenever reassembling.
- **REMOVING** and installing the blade hub may cause an imbalance.

### 7.5.1 BLADE REMOVAL

Maintenance of the blades and inspection of the fasteners used can be done without the removal of the blade hub and blade beams.

**Step one:** Follow “5.2 Removing the 4FT Slasher” to place the slasher on sufficient blocking to access the blades for removal.

**Step two:** Loosen the locking bolt on the inspection port and rotate the inspection port plate to the side as seen on the next page.

**Step three:** Rotate the blade assembly clockwise until the blade fastener is under the inspection port (The clutch should make a clicking noise).

**Step four:** Using an extended socket wrench undo the nut and lightly tap the top of the bolt until it falls free.

**Step five:** Remove the blade from the blade hub and the bolt from the ground.

**Step six:** Repeat steps three, four and five until all desired blades are removed.

## 7.6 BLADE INSTALLATION

**Step one:** Follow “5.2 Removing the 4FT Slasher” to place the slasher on sufficient blocking to support the attachment and allow access to install the blades.

**Step two:** Check all new fasteners to ensure they are clean, dry, and lubricant free.

**Step three:** Place hardened bush into the blade mounting point and slide the blade into place between the two beams.

**Step four:** Secure the blade by inserting the nib bolt from below and tightening on the tapered nut enough to hold the bolt in place.

**Step five:** Rotate the blade assembly and repeat Steps three and four until all blades are in place.

**Step six:** Using an extended socket wrench through the inspection port hole tighten the tapered nuts (recommended torque: 200Nm).

**Step seven:** Rotating the blade assembly repeat the tightening on all nuts until fasteners are correctly torqued.

**Step eight:** Rotate the inspection port cover back into place and tighten locking bolt.

**Step nine:** Follow “5.1 Hitching Up the 4FT Slasher” (Take extra care during initial motor testing for excessive vibration caused by misalignment).

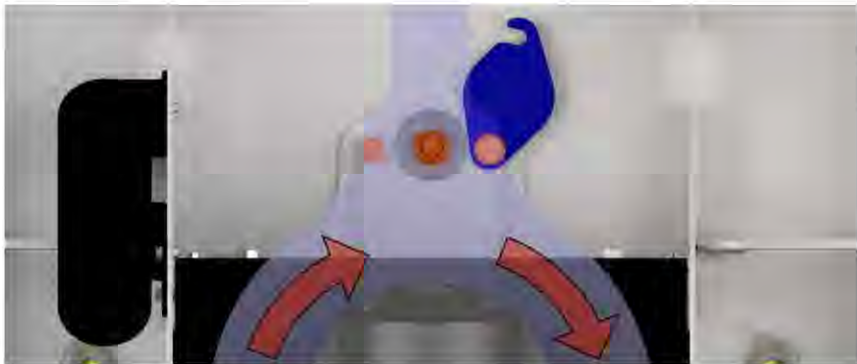

## 7.6.1 BLADE HUB DISASSEMBLY

**Step one:** Follow “5.2 Removing the 4FT Slasher” to place the slasher on sufficient blocking to support the attachment and allow access to the blade assembly below.

**Step two:** Secure blade assembly from falling and the blades from rotating.

**Step three:** Remove the three bolts holding the locking collar.

**Step four:** Remove the six central bolts which will allow the blade hub to be lowered and moved to a clear working area.



**Step five:** Remove the three tapered nuts to allow each blade beam to be assessed and replaced.

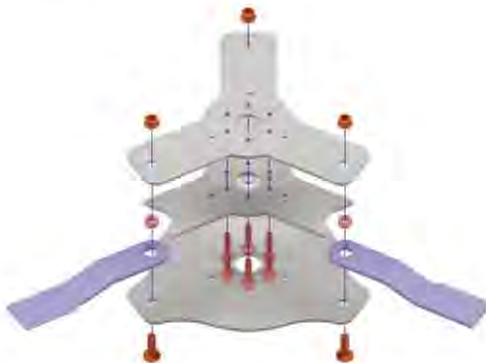

## 7.6.2 BLADE HUB ASSEMBLY & INSTALLATION

**Step one:** Prepare a clear and safe working environment in which to assemble the blade hub and check all fasteners are new, ensuring they are clean, dry, and lubricant free.

**Step two:** Apply Blue Loctite (242) to the six centre bolts.

**Step three:** Place the six centre bolts and nib bolts in the bottom beam.

**Step four:** Stack the middle spacer plate, hardened bushes, blades, and top beam onto the bolts and tighten the tapered nuts to a torque of 200Nm, locking the assembly together (As seen on previous page).

**Step five:** Secure the blades, preventing them from rotating in the blade hub.

**Step six:** With the slasher on sufficient safe blocking, lift and secure assembly to the gearbox so that it can't move during installations. Take time to ensure the hub is centred on the gearbox.

**Step seven:** Using a torque wrench, tighten each bolt to 160ft-lbs in a crosswise pattern.

**Step eight:** Repeat Step seven.

**Step nine:** Attempt to install the bolt locking collar. Note how far out of align each bolt is.

**Step ten:** Tighten each bolt until the bolt locking collar fits over each bolt head.

**Step eleven:** Fasten the thread locking collar using bolts, washers and Nyloc nuts.

**Step twelve:** Remove securing devices from the blade hub and follow "5.1 Hitching Up the 5FT Slasher" (Take extra care during initial motor testing. Look for early signs of excessive vibration).

# 8 RISK ASSESSMENT

Assessment Team: Norman Pesch, John Pesch, Sam Ramsden

Date of Assessment: 28/04/2022

Manufacturer: Norm Engineering Pty Ltd

Location: Brisbane

Contact Person: Norman Pesch

Attachment: 4ft Slasher

Weight: 280-370kg

Intended use: Slashing Grass

Construction material: Steel

Air Operated: NO

Hydraulic Operated: YES

Manually operated: NO

NOTE: When assessing Risk, you **MUST** consider the following

Inherent Risk:

(Risk before ANY controls). I.e., Before guarding / safety features are fitted.

Residual Risk:

(Risk after controls are fitted). I.e., after guarding / safety features are fitted.

Non Standard Operating Risk:

(Cleaning, Maintenance). I.e., What other risks can these tasks create.

Predictable Misuse:

I.e., What risks could occur due to misuse of the attachment.

## HAZARD INFORMATION

The plant must be assessed against the hazards listed for the probability of harm to operators working in close proximity and the environment.

### Probability

- A – Common or repeating occurrence
- B – Known to occur or “It has happened”
- C – Could occur, “I’ve heard of it happening”
- D – Not likely to occur
- E – Practically impossible

### Consequence

- 1 – Catastrophic – Fatalities
- 2 – Major – Major injury, LTI
- 3 – Moderate – Minor Injury
- 4 – Minor – First aid, slight injury
- 5 – Insignificant – Minimal risk of injury

	A	B	C	D	E
1	H	H	H	S	S
2	H	H	S	S	M
3	H	H	S	M	L
4	H	S	M	L	L
5	S	S	M	L	L

H = High

S = Significant

M = Medium

L = Low

### Entanglement:

<p>Can anyone's hair, clothing gloves, necktie, jewellery, rags, and other materials become entangled with moving parts of plant, or materials in motion?</p> <p><b>People in close proximity to the plant and plant attachment during operation have the ability to become entangled, i.e., HYD. motors, clutch, gearbox, and rotating plates.</b></p>	Yes <input checked="" type="checkbox"/> No <input type="checkbox"/>	A	<input type="checkbox"/>	1	<input type="checkbox"/>	High Significant Medium Low	<input checked="" type="checkbox"/> <input type="checkbox"/> <input type="checkbox"/> <input type="checkbox"/>
		B	<input type="checkbox"/>	2	<input checked="" type="checkbox"/>		
		C	<input type="checkbox"/>	3	<input type="checkbox"/>		
		D	<input checked="" type="checkbox"/>	4	<input type="checkbox"/>		
		E	<input type="checkbox"/>	5	<input type="checkbox"/>		

### Crushing:

<p>Can anyone be crushed due to falling, uncontrolled or unexpected movement of plant attachment or its load, lack of capacity to slow, stop or immobilise the plant, tipping or rolling over, parts of plant attachment collapsing, contact with moving parts during testing, inspection, maintenance, cleaning, or repair, thrown off, under or trapped between plant and materials or fixed structures?</p> <p><b>People in close proximity to the plant and plant attachment during operation could be crushed if the operator is not being sufficiently observant, or control over the plant is lost.</b></p>	Yes <input checked="" type="checkbox"/> No <input type="checkbox"/>	A	<input type="checkbox"/>	1	<input type="checkbox"/>	High Significant Medium Low	<input type="checkbox"/> <input checked="" type="checkbox"/> <input type="checkbox"/> <input type="checkbox"/> <input type="checkbox"/>
		B	<input type="checkbox"/>	2	<input checked="" type="checkbox"/>		
		C	<input type="checkbox"/>	3	<input type="checkbox"/>		
		D	<input checked="" type="checkbox"/>	4	<input type="checkbox"/>		
		E	<input type="checkbox"/>	5	<input type="checkbox"/>		

### Cutting, Stabbing, Puncturing:

<p>Can anyone be cut, stabbed, or punctured by coming in contact with moving plant or parts, sharp or flying objects, work pieces ejected, work pieces disintegrated, or other factors not mentioned?</p> <p><b>People can be cut, stabbed, or punctured by coming into contact with projectiles flung from the rotating broom.</b></p>	Yes <input checked="" type="checkbox"/> No <input type="checkbox"/>	A	<input type="checkbox"/>	1	<input type="checkbox"/>	High Significant Medium Low	<input type="checkbox"/> <input checked="" type="checkbox"/> <input type="checkbox"/> <input type="checkbox"/> <input type="checkbox"/>
		B	<input type="checkbox"/>	2	<input checked="" type="checkbox"/>		
		C	<input type="checkbox"/>	3	<input type="checkbox"/>		
		D	<input checked="" type="checkbox"/>	4	<input type="checkbox"/>		
		E	<input type="checkbox"/>	5	<input type="checkbox"/>		

### Striking:

<p>Can anyone be struck by moving objects due to plant or work pieces being ejected or disintegrated, mobility, uncontrolled or unexpected movement of the plant or other factors?</p> <p><b>People in close proximity to the plant and plant attachment during operation could be seriously hurt if they came into contact with the plant, or plant attachment if the operator is not being sufficiently observant, or control over the plant is lost.</b></p>	Yes <input checked="" type="checkbox"/> No <input type="checkbox"/>	A	<input type="checkbox"/>	1	<input type="checkbox"/>	High Significant Medium Low	<input checked="" type="checkbox"/> <input checked="" type="checkbox"/> <input type="checkbox"/> <input type="checkbox"/> <input type="checkbox"/>
		B	<input checked="" type="checkbox"/>	2	<input checked="" type="checkbox"/>		
		C	<input type="checkbox"/>	3	<input type="checkbox"/>		
		D	<input type="checkbox"/>	4	<input type="checkbox"/>		
		E	<input type="checkbox"/>	5	<input type="checkbox"/>		



### Slipping, Tripping, Falling:

<p>Can anyone using the plant or in the vicinity of the plant, slip, trip or fall due to the working environment or other factors? poor housekeeping, dust on the floor around machines, slippery or uneven work surfaces or lack of guardrails.</p> <p><b>People standing on the plant attachment could slip or fall from it.</b></p>	Yes	No	A	<input type="checkbox"/>	1	<input type="checkbox"/>	High Significant Medium Low	<input type="checkbox"/>
	<input checked="" type="checkbox"/>	<input type="checkbox"/>	B	<input type="checkbox"/>	2	<input type="checkbox"/>		<input type="checkbox"/>
			C	<input type="checkbox"/>	3	<input checked="" type="checkbox"/>		<input type="checkbox"/>
			D	<input checked="" type="checkbox"/>	4	<input type="checkbox"/>		<input type="checkbox"/>
			E	<input type="checkbox"/>	5	<input type="checkbox"/>		<input type="checkbox"/>
								<input type="checkbox"/>

### Shearing:

<p>Can anyone's body parts be cut off between two parts of the plant, or between a part of the plant and a work piece or structure? For example, on a metal guillotine can a finger fit under the guard.</p> <p><b>People not following SOP's or plant guidelines could become injured from misuse or working in the vicinity of the plant and plant attachment.</b></p>	Yes	No	A	<input type="checkbox"/>	1	<input checked="" type="checkbox"/>	High Significant Medium Low	<input type="checkbox"/>
	<input checked="" type="checkbox"/>	<input type="checkbox"/>	B	<input type="checkbox"/>	2	<input type="checkbox"/>		<input type="checkbox"/>
			C	<input type="checkbox"/>	3	<input type="checkbox"/>		<input type="checkbox"/>
			D	<input checked="" type="checkbox"/>	4	<input type="checkbox"/>		<input type="checkbox"/>
			E	<input type="checkbox"/>	5	<input type="checkbox"/>		<input type="checkbox"/>
								<input type="checkbox"/>

### Friction:

<p>Can anyone be burnt due to contact with moving parts or surfaces of the plant, or material handled by the plant? For example, on the grinder is there more than 1 mm gap between the tool rest and the wheel?</p> <p><b>People could be burned by rotating parts if correct SOP's are not followed.</b></p>	Yes	No	A	<input type="checkbox"/>	1	<input type="checkbox"/>	High Significant Medium Low	<input type="checkbox"/>
	<input checked="" type="checkbox"/>	<input type="checkbox"/>	B	<input type="checkbox"/>	2	<input type="checkbox"/>		<input type="checkbox"/>
			C	<input type="checkbox"/>	3	<input checked="" type="checkbox"/>		<input type="checkbox"/>
			D	<input checked="" type="checkbox"/>	4	<input type="checkbox"/>		<input type="checkbox"/>
			E	<input type="checkbox"/>	5	<input type="checkbox"/>		<input type="checkbox"/>
								<input type="checkbox"/>

### High Pressure Fluid:

<p>Can anyone come into contact with fluids under high pressure, due to plant failure or misuse of the plant?</p> <p><b>The plant attachment utilizes the plants high pressure hydraulic system, if a failure occurs it is possible to come into contract with high pressure fluid.</b></p>	Yes	No	A	<input type="checkbox"/>	1	<input type="checkbox"/>	High Significant Medium Low	<input type="checkbox"/>
	<input checked="" type="checkbox"/>	<input type="checkbox"/>	B	<input type="checkbox"/>	2	<input checked="" type="checkbox"/>		<input type="checkbox"/>
			C	<input type="checkbox"/>	3	<input type="checkbox"/>		<input type="checkbox"/>
			D	<input checked="" type="checkbox"/>	4	<input type="checkbox"/>		<input type="checkbox"/>
			E	<input type="checkbox"/>	5	<input type="checkbox"/>		<input type="checkbox"/>
								<input type="checkbox"/>

### Electrical:

<p>Can anyone be injured by electrical shock or burnt due to damaged or poorly maintained leads or switches, water near electrical equipment, working near or contact with live electrical conductors, lack of isolation procedures or the factors not mentioned? For example, are any switches broken, is there a red emergency stop? Can each machine be locked off for repairs?</p>	Yes	No	A	<input type="checkbox"/>	1	<input type="checkbox"/>	High Significant Medium Low	<input type="checkbox"/>
	<input type="checkbox"/>	<input checked="" type="checkbox"/>	B	<input type="checkbox"/>	2	<input type="checkbox"/>		<input type="checkbox"/>
			C	<input type="checkbox"/>	3	<input type="checkbox"/>		<input type="checkbox"/>
			D	<input type="checkbox"/>	4	<input type="checkbox"/>		<input type="checkbox"/>
			E	<input type="checkbox"/>	5	<input type="checkbox"/>		<input type="checkbox"/>
								<input type="checkbox"/>

**Dust:**

<p>Can anyone suffer ill health or injury due to exposure to dust?                  For example, cutting, living silica                  Lack of vision – External influences causing the dust.                  Plant operation causing the dust.</p> <p><b>Depending on the operation location of the plant and plant attachment dust could be a nuisance.</b></p>	Yes <input checked="" type="checkbox"/> No <input type="checkbox"/>	A	<input type="checkbox"/>	1	<input type="checkbox"/>	High <input type="checkbox"/> Significant <input checked="" type="checkbox"/> Medium <input type="checkbox"/> Low <input type="checkbox"/>
		B	<input type="checkbox"/>	2	<input checked="" type="checkbox"/>	
		C	<input checked="" type="checkbox"/>	3	<input type="checkbox"/>	
		D	<input type="checkbox"/>	4	<input type="checkbox"/>	
		E	<input type="checkbox"/>	5	<input type="checkbox"/>	

**Noise:**

<p>Can anyone suffer hearing discomforts while the plant is in use? For example, the plant is noisy, and it is difficult to hear.</p> <p><b>Depending on the grass the plant attachment is operated on the friction could lead to excessive noise which could lead to confusion or even hearing damage.</b></p>	Yes <input checked="" type="checkbox"/> No <input type="checkbox"/>	A	<input type="checkbox"/>	1	<input type="checkbox"/>	High <input type="checkbox"/> Significant <input checked="" type="checkbox"/> Medium <input type="checkbox"/> Low <input type="checkbox"/>
		B	<input type="checkbox"/>	2	<input type="checkbox"/>	
		C	<input checked="" type="checkbox"/>	3	<input checked="" type="checkbox"/>	
		D	<input type="checkbox"/>	4	<input type="checkbox"/>	
		E	<input type="checkbox"/>	5	<input type="checkbox"/>	

**Vibration:**

<p>Can anyone suffer injury due to the vibration of the plant?</p> <p><b>The plant attachment could cause excessive vibration if it is operated whilst damaged or not correctly maintained.</b></p>	Yes <input checked="" type="checkbox"/> No <input type="checkbox"/>	A	<input type="checkbox"/>	1	<input type="checkbox"/>	High <input type="checkbox"/> Significant <input checked="" type="checkbox"/> Medium <input type="checkbox"/> Low <input type="checkbox"/>
		B	<input type="checkbox"/>	2	<input type="checkbox"/>	
		C	<input checked="" type="checkbox"/>	3	<input checked="" type="checkbox"/>	
		D	<input type="checkbox"/>	4	<input type="checkbox"/>	
		E	<input type="checkbox"/>	5	<input type="checkbox"/>	

**Environmental:**

<p>Can the plant operation cause an environmental issue? For example – pollution, waste materials, noise.</p>	Yes <input type="checkbox"/> No <input checked="" type="checkbox"/>	A	<input type="checkbox"/>	1	<input type="checkbox"/>	High <input type="checkbox"/> Significant <input type="checkbox"/> Medium <input type="checkbox"/> Low <input type="checkbox"/>
		B	<input type="checkbox"/>	2	<input type="checkbox"/>	
		C	<input type="checkbox"/>	3	<input type="checkbox"/>	
		D	<input type="checkbox"/>	4	<input type="checkbox"/>	
		E	<input type="checkbox"/>	5	<input type="checkbox"/>	

**Risk Evaluation**

Overall risk category of plant:	High	<b>Significant</b>	Medium	Low
---------------------------------	------	--------------------	--------	-----

**Risk Controls**

Most Desirable

- |   |   |
|---|---|
| <p>↓</p> <ul style="list-style-type: none"> <li>• Elimination</li> <li>• Substitution</li> <li>• Engineering Controls</li> <li>• Isolation</li> <li>• Administrative Controls</li> <li>• PPE</li> </ul> | <ul style="list-style-type: none"> <li>- The best way to eliminate the risk is to remove the hazard.</li> <li>- Substitute the hazardous plant with a safer part, alternative process.</li> <li>- Design modification, installation of guarding, automation/ventilation.</li> <li>- Isolate the plant, barricades, crossing, bunting, etc.</li> <li>- Permits, clearances, lock out systems, certification.</li> <li>- Short term control measure.</li> </ul> |
|---|---|

Least Desirable

Hazard	Controls
Entanglement	<p>Engineering Controls – A guard plate has been added to cover any rotating components to prevent accidents from happening.</p> <p>Isolation – Ensure the operating and maintenance manual provided with the plant attachment recommends the operator of the plant always follows SOP. The operator must make everybody working in the vicinity of the attachment aware of the dangers and before moving the plant ensure people are safe distance away.</p> <p>PPE – Ensuring all people who will be in the vicinity of the plant attachment during operation be wearing clothes with no loose ends that can become entangled in the plant attachment.</p>
Crushing, Striking	<p>Isolation – Ensure the operating and maintenance manual provided with the plant attachment recommends the operator of the plant always follows SOP. The operator must make everybody working in the vicinity of the attachment aware of the dangers and before moving the plant ensure people are safe distance away.</p> <p>PPE – The use of the correct PPE for the worksite will minimize the damage caused by an incident. A hard hat, steel cap boots and tough worksite clothes as an example.</p> <p>PPE – The use of high visibility PPE will help reduce the case of incidents occurring from impaired vision or operator distraction.</p>
Cutting, Stabbing, Puncturing	<p>Engineering Controls – Chains have been added to stop projectiles from being able to escape from under the plant attachment at speed.</p> <p>Isolation – Ensure the operating and maintenance manual provided with the plant attachment recommends the operator of the plant always follows SOP. The operator must make everybody working in the vicinity of the attachment aware of the dangers and before moving the plant ensure people are safe distance away.</p> <p>PPE – The use of the correct PPE for the worksite will minimize the risk of cutting when working in and around the plant attachment. Safety glasses, and tough worksite clothes will reduce the risk associated with debris being shot out from under the plant attachment.</p>
Slipping, Tripping, Falling	<p>Isolation – The plant attachment has NOT been designed to stand on unless entering or exiting the plant. This will be stated in the operating and maintenance manual. It is the responsibility of the operator to ensure that no persons stand on the plant attachment.</p> <p>PPE – Wearing the correct work boots will reduce chances of slipping.</p>

<p>Shearing</p>	<p>Engineering Controls – A guard plate has been added to cover any rotating components to prevent accidents from happening.</p> <p>Isolation – Ensure the operating and maintenance manual provided with the plant attachment recommends the operator of the plant always follows SOP. The operator must make everybody working in the vicinity of the attachment aware of the dangers and before moving the plant ensure people are safe distance away.</p> <p>Administrative Controls – A warning sticker should be placed in a visible position on the plant attachment highlighting the potential risk.</p>
<p>Friction</p>	<p>Engineering Controls – A guard plate has been added to cover any rotating components to prevent accidents from happening.</p> <p>PPE – Wearing protective gloves will reduce any damage from touching heated components.</p>
<p>High Pressure Fluid</p>	<p>Engineering Controls – The routing of the hydraulic hoses and the design of the plates which guard the hydraulic motor minimize the risk of the hydraulic failure and exposure to high pressure fluids.</p> <p>Administrative Controls – The manual will address correct maintenance schedules for the plant attachment hydraulics to reduce the risk associated with hydraulic component failure. Only authorized hydraulics fitters should perform repairs on hydraulic systems.</p> <p>Administrative Controls – A warning sticker should be placed in a visible position on the plant attachment highlighting the potential risk.</p>
<p>Dust</p>	<p>Isolation and Administrative Controls – To reduce the hazards associated with dust, the manual should instruct the operator to consider their working environment and operate in a manner to reduce the risk of dust being kicked up. This can be managed by operating at a sensible speed.</p> <p>PPE – If the environment is such that the dust cannot be sufficiently controlled, the onsite supervisor should ensure all workers are wearing the correct PPE.</p>
<p>Noise</p>	<p>PPE – To reduce the risk associated with excessive noise the correct PPE should be worn whilst operating or being within a vicinity of the plant and plant attachment during operations.</p>
<p>Vibration</p>	<p>Administrative Controls – A regular maintenance schedule will help prevent from issues such as misalignment or uneven wear which causes excessive vibration.</p>

## **Any Modification to Plant Attachment Voids Risk Assessment**

**Purchaser and User are required to conduct their own risk assessment to identify hazards prior to use.**

This risk assessment does not necessarily cover all possible hazards associated with this product and should be utilized in conjunction with the purchasers and users individual risk assessments to identify all environmental, health, and safety risks associated with specific tasks, locations, and personnel.

# 9 PARTS

## QUALITY BACKUP

*We manufacture 90% of our parts inhouse.  
This means we can get your parts to you... quickly.*

### 9.1 ORDERING PARTS

For ordering parts contact either your dealer or Norm Engineering directly. Contact details are included at the front of this manual. To assist, note the details of your 4ft slasher in the spaces provided under *Section 9.1.1 Reference Information*.

#### 9.1.1 REFERENCE INFORMATION

Always refer to the model and serial number when ordering parts or requesting from you dealer. The serial number for this product is located on the identification place of your 4ft slasher.

Model Number:

.....

Make:

.....

Serial Number:

.....

Date Purchased:

.....

# 10 PARTS LIST

When ordering replacement parts, please include the following information:

- The machine make and model
- The serial number on the attachment
- The item number, as indicated by the following figures and tables.
- Parts with a part number of “..” indicate a component that varies dependent on machine make and model. A serial number and item number is essential if ordering these parts.

Items numbers with a “R” before the number indicate parts that require specialty tools and some knowledge in fabrication and welding to replace.

## 4FT SLASHER (SKID-STEER) PARTS LIST

Item	Part Number	QTY	Description	Diagram
1	NSL4000	1	4FT SLASHER – MAIN BODY	1
2	..	1	4FT SLASHER – MOTOR & BLADES	1
3	NSL4085	1	4FT SLASHER – WHEEL KIT	1
4	NSL4089	1	4FT SLASHER – PICKUP FRAME	1
5	NSL5001	17	FRONT CHAIN	1
6	NSL5002	15	REAR CHAIN	1
7	NSL4035	1	4FT SLASHER – GEARBOX/CLUTCH COVER	1
8	NSL4074	1	4FT SLASHER – NORM ENG COLOUR PLATE	1
9	NSL5046	1	INSPECTION PORT COVER	1
10	NSL4030	1	12mm ROUND BAR – 400mm LENGTH	1
11	NSL4031	2	12mm ROUND BAR – 600mm LENGTH	1
12	NSL4032	1	12mm ROUND BAR – 1220mm LENGTH	1
13	B1970	1	BARE CO. DOCUMENT HOLDER	1
14	NSL5064	9	CHAIN HOLDING BRACKET W/ BOLT KIT	1
15	-	2	STOPPER W/ BOLT KIT	1
16	-	2	BOLT KIT – FRONT GEARBOX/CLUTCH COVER	1
17	-	4	BOLT KIT – NORM ENG COLOUR PLATE	1
18	-	2	BOLT KIT – REAR GEARBOX/CLUTCH COVER	1
19	-	3	BOLT KIT – DOCUMENT HOLDER	1
20	-	1	BOLT KIT – INSPECTION PORT	1

THE PRODUCT IMAGES ARE FOR ILLUSTRATIVE PURPOSES ONLY AND MAY NOT BE AN EXACT REPRESENTATION OF THE PRODUCT. NORM ENG. RESERVES THE RIGHT TO CHANGE PRODUCT IMAGES AND SPECIFICATIONS AT ANY TIME WITHOUT NOTICE.

4FT SLASHER (SKID-STEER)

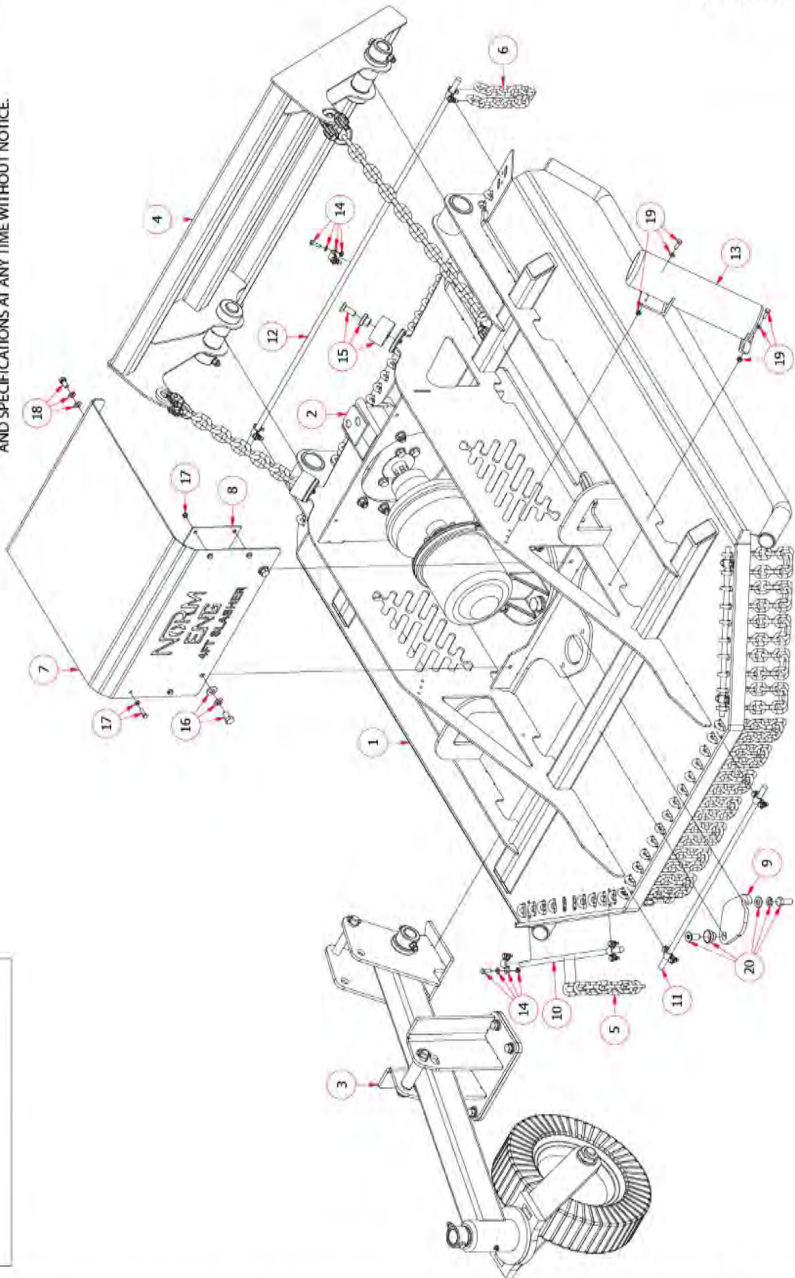



#### 4FT SLASHER (SKID-STEER) PICKUP PARTS LIST

Item	Part Number	QTY	Description	Diagram
1	NSL4056	1	4FT SLASHER – PICKUP FRAME	2
2	NSL4048	2	18 LINK UNIVERSAL PLATE CONNECTOR	2
3	BU040	2	84mm NYLON BUSH INSERT	2
4	PI081	2	SLASHER PICKUP PIN	2
5	-	2	BOLT KIT – SLASHER PICKUP PIN	2

**Diagram 2**

4FT SLASHER (SKID-STEER)  
PICKUP

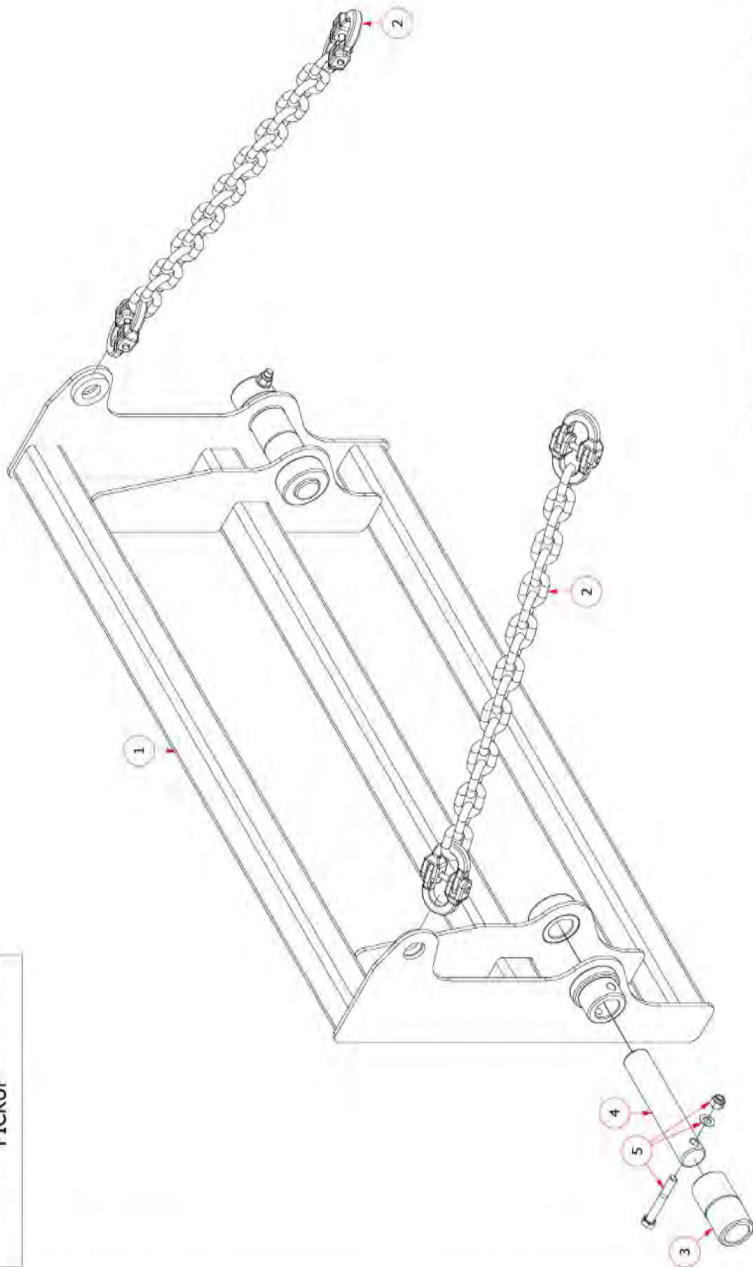

THE PRODUCT IMAGES ARE FOR ILLUSTRATIVE PURPOSES ONLY AND MAY NOT BE AN EXACT REPRESENTATION OF THE PRODUCT. NORM ENG. RESERVES THE RIGHT TO CHANGE PRODUCT IMAGES AND SPECIFICATIONS AT ANY TIME WITHOUT NOTICE.

4FT SLASHER (SKID-STEER) BLADE ASSEMBLY PARTS LIST

Item	Part Number	QTY	Description	Diagram
1	NSL4090	2	3 BLADE TOP BLADE BEAM	3
2	NSL4091	1	3 BLADE CENTRE BLADE BEAM	3
3	NSL4092	2	3 BLADE BOTTOM BLADE BEAM	3
4	NSL4093	1	3 BLADE BOLT COLAR PLATE	3
5	∴	1	MOTOR PLATE	3
6	∴	1	HYDRAULIC MOTOR	3
7	∴	1	GEARBOX	3
8	∴	1	CLUTCH	3
9	BS-01724	2	ASP – SUCTION LIFT BLADE LHC	3
10	-	4	BOLT KIT – HYDRAULIC MOTOR	3
11	-	6	BOLT KIT – MOTOR PLATE	3
12	-	4	BOLT KIT – GEARBOX	3
13	-	3	BOLT KIT – BLADE HOWARD NIB SET	3
14	-	4	BOLT KIT – BLADE BEAM CLAMP	3
15	-	3	BOLT KIT – LOCKING PLATE	3

**4FT SLASHER  
TRI-BLADE ASSEMBLY**

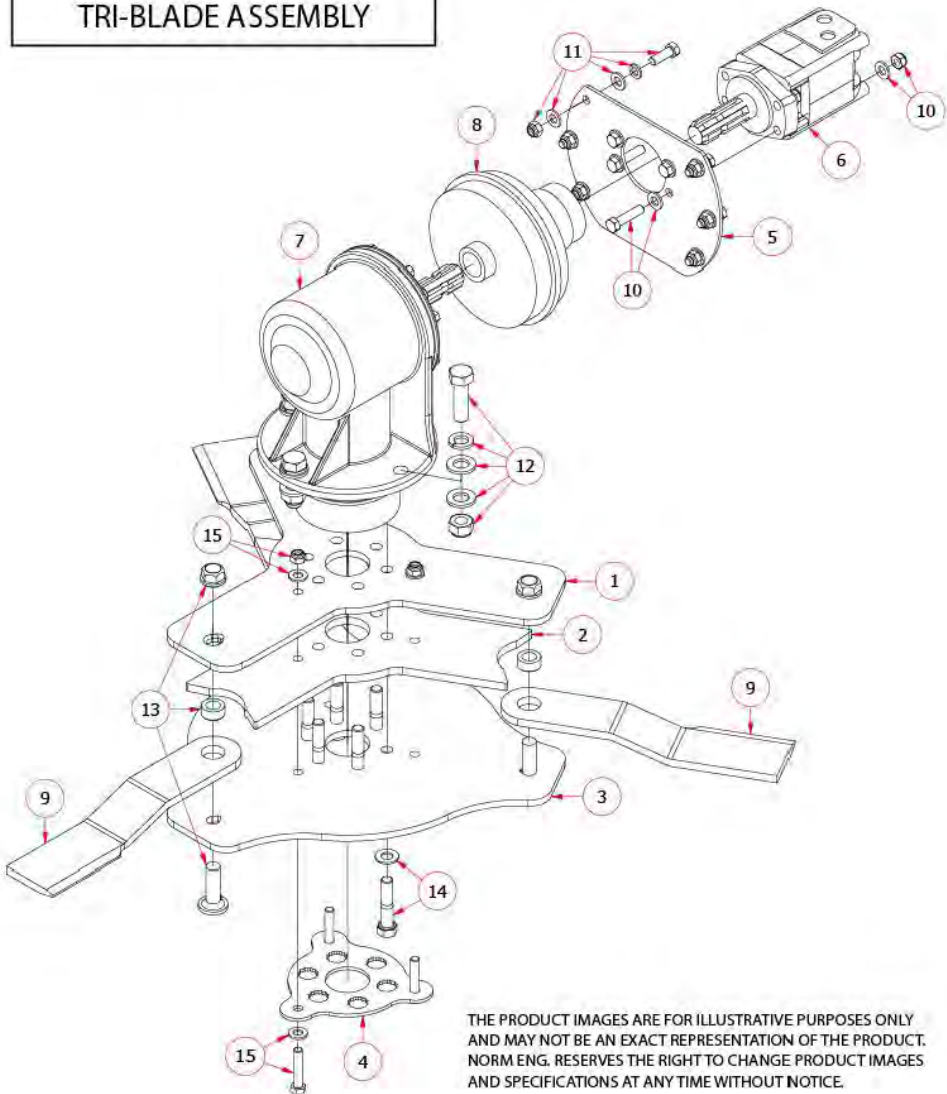

#### 4FT SLASHER WHEEL KIT PARTS LIST

Item	Part Number	QTY	Description	Diagram
1	NSL4082	1	4FT WHEEL KIT – ARM PIVOT & LOCK PLATE	4
2	NSL4081	1	4FT WHEEL KIT – HEIGHT ADJUSTMENT	4
3	NSL4084	1	4FT WHEEL KIT – WHEEL ARM	4
4	NSL5011	1	4FT WHEEL KIT – PIVOT MOUNT	4
5	NSL4079	1	4FT WHEEL KIT – MOUNTING PLATE	4
6	B6440-1	1	SLASHER WHEEL	4
7	B74-1	2	HEIGHT LOCKING PIN	4
8	B74-2	2	LINCH PIN	4
9	CASE580	2	1 1/2" HARDEN BUSH INSERT	4
10	BU040	1	84mm BYLON BUSH INSERT	4
11	RE014	1	WHEEL ARM RETAINER	4
12	PI142	1	WHEEL ARM PIVOT PIN	4
13	NS2001	1	3/8" GREASE NIPPLE	4
14	B6440-2	1	BOLT KIT – WHEEL	4
15	-	2	BOLT KIT – WHEEL PIVOT/ARM PIVOT PIN	4
16	-	4	BOLT KIT – HEIGHT ADJUSTMENT	4

THE PRODUCT IMAGES ARE FOR ILLUSTRATIVE PURPOSES ONLY AND MAY NOT BE AN EXACT REPRESENTATION OF THE PRODUCT. NORM ENG. RESERVES THE RIGHT TO CHANGE PRODUCT IMAGES AND SPECIFICATIONS AT ANY TIME WITHOUT NOTICE.

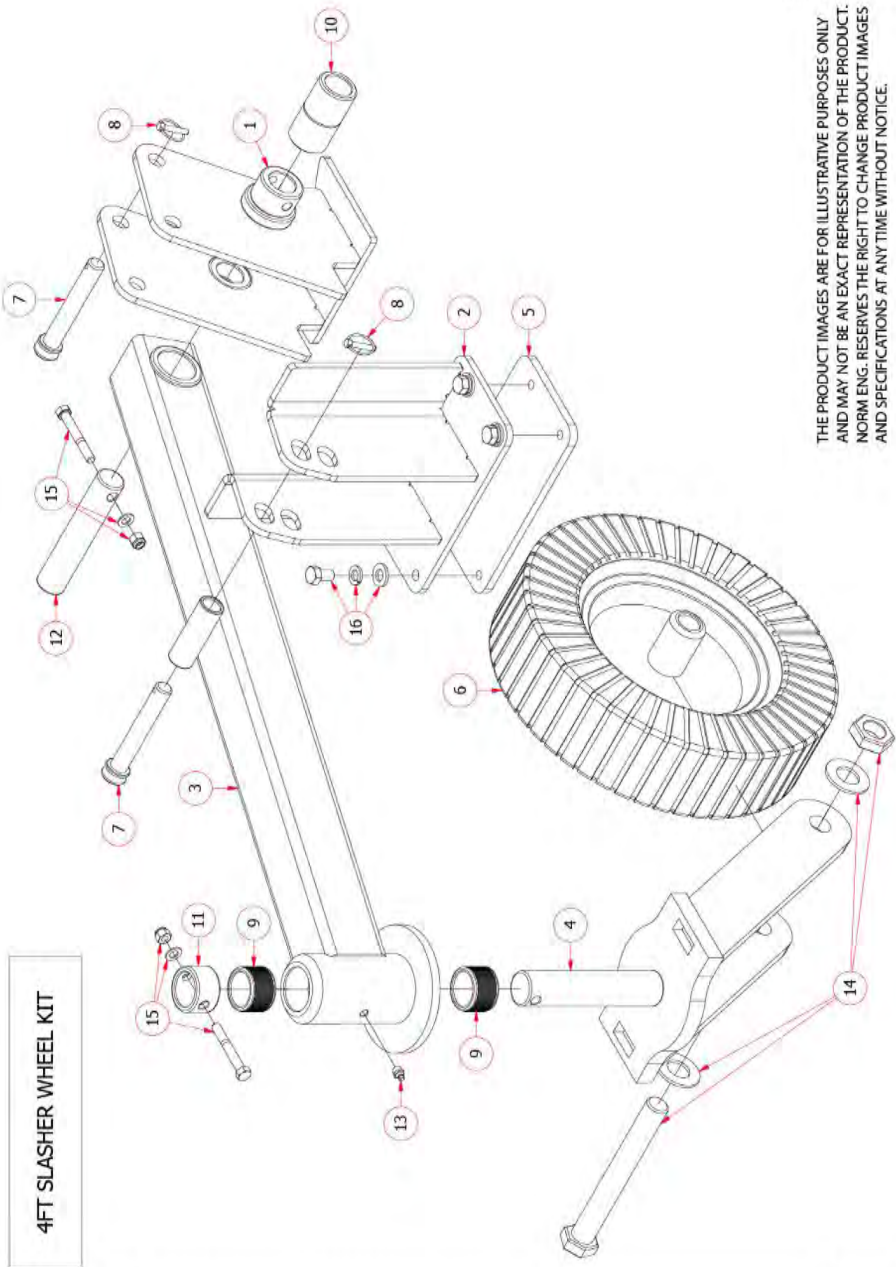

#### 4FT SLASHER (EXCAVATOR) PARTS LIST

Item	Part Number	QTY	Description	Diagram
1	NSL4000EX	1	4FT SLASHER – MAIN BODY (EXCAVATOR)	5
2	..	1	4FT SLASHER – MOTOR & BLADE	5
3	NSL5001	17	FRONT CHAIN	5
4	NSL5002	15	REAR CHAIN	5
5	NSL4014	1	GEARBOX/CLUTCH COVER (EXCAVATOR)	5
6	NSL5044	1	NORM ENG COLOUR PLATE (EXCAVATOR)	5
7	NSL4012	1	UNIVERSAL PICKUP PLATE (EXCAVATOR)	5
8	NSL4023	2	UNIVERSAL STEP PLATE (EXCAVATOR)	5
9	NSL5046	1	INSPECTION PORT COVER	5
10	NSL4030	2	12mm ROUND BAR – 400mm LENGTH	5
11	NSL4031	1	12mm ROUND BAR – 600mm LENGTH	5
12	NSL4032	1	12mm ROUND BAR – 1220mm LENGTH	5
13	B1970	1	BARE CO. DOCUMENT HOLDER	5
14	-	2	STOPPER W/ BOLT KIT	5
15	-	9	CHAIN HOLDING BRACKET W/ BOLT KITS	5
16	-	1	BOLT KIT – INSPECTION PORT	5
17	-	2	BOLT KIT – FRONT GEARBOX/CLUTCH COVER	5
18	-	4	BOLT KIT – NORM ENG COLOUR PLATE	5
19	-	4	BOLT KIT – TOP GEARBOX/CLUTCH COVER	5
20	-	6	BOLT KIT – UNIVERSAL PICKUP PLATE	5
21	-	3	BOLT KIT – DOCUMENT HOLDER	5

THE PRODUCT IMAGES ARE FOR ILLUSTRATIVE PURPOSES ONLY AND MAY NOT BE AN EXACT REPRESENTATION OF THE PRODUCT. NORM ENG. RESERVES THE RIGHT TO CHANGE PRODUCT IMAGES AND SPECIFICATIONS AT ANY TIME WITHOUT NOTICE.

**4FT SLASHER (EXCAVATOR)**

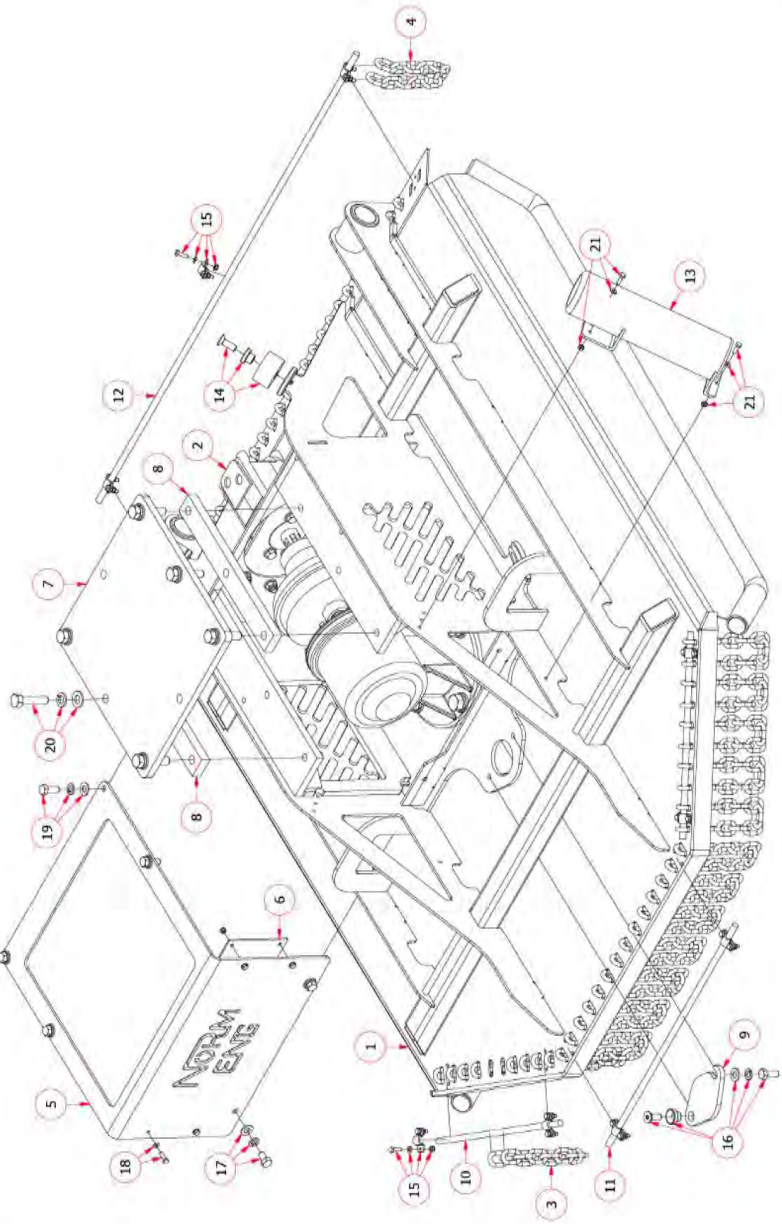



## 4FT SLASHER HYDRAULIC PARTS LIST

Item	Part Number	QTY	Description	Diagram
1	..	1	HYDRAULIC MOTOR	6
2	M A13 1/2 BSP	1	1/2" FLAT FACE STUCCHI MALE	6
3	F A13 1/2 BSP	1	1/2" FLAT FACE STUCCHI FEMALE	6
4	F A7 1/4 BSP	1	1/4" FLAT FACE STUCCHI FEMALE	6
5	G-BP-45-1408	2	45 – ADAPTOR – 1/2" BSPPM – 7/8" JICM	6
6	G-N-0904	2	ST – ADAPTOR – 1/4" BSPPM – 9/16" JICM	6
7	G-N-1414	2	ST – ADAPTOR – 7/8" UNOM – 7/8" JICM	6
H1	..	1	HYD. HOSE MALE COUPLER TO HYD. MOTOR	6
H2	..	1	HYD. HOSE FEMALE COUPLER TO HYD. MOTOR	6
H3	..	1	HYD. HOSE FEMALE COUPLER TO CASE DRAIN	6

**Diagram 6**

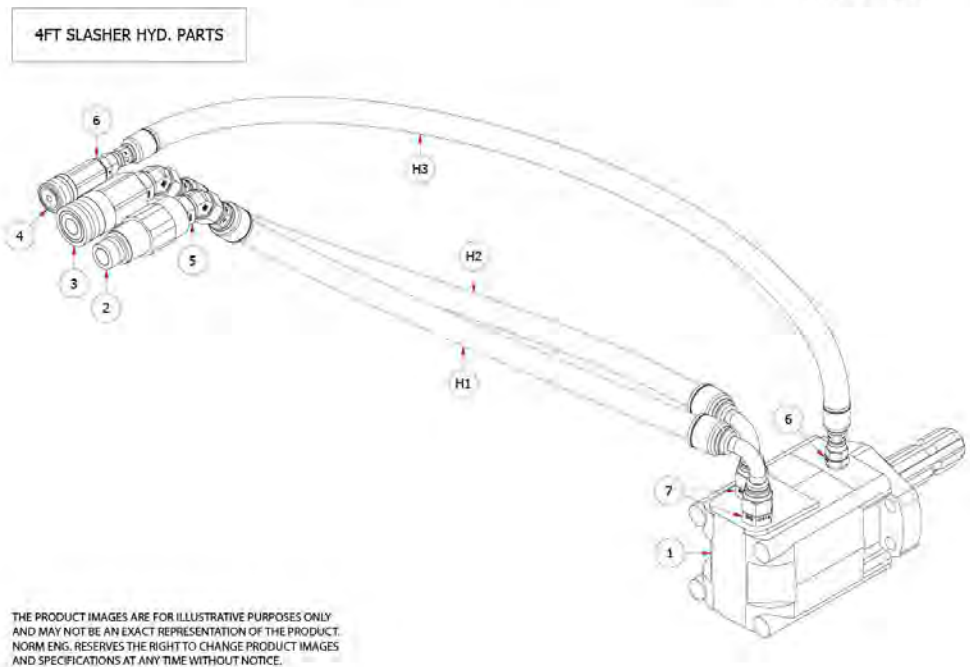

# 11 APPENDICES

## 11.1 SAFETY SIGN LOCATIONS

Item	Description
1	Warning   Pinch point
2	Danger   High pressure fluid
3	Warning   Attachment can contact machine
4	Danger   Read the Manual



ITEM 1



ITEM 2



ITEM 3



ITEM 4

### Instructions

- Keep all safety signs clear and legible.
- Replace all missing, illegible, or damaged safety signs.
- When replacing parts which have safety signs attached make sure the replacement part has the safety sign.

# 12 WARRANTY

## 12.1 DEFINITION

“**Dealer**” means a dealer that purchases products directly from Norm Engineering Pty Ltd.

“**End consumer**” means a consumer that purchases products either directly from Norm Engineering Pty Ltd or directly from a “dealer” as defined above.

“**Products**” includes goods and services.

## 12.2 WARRANTY

Norm Engineering Pty Ltd welcomes you as a purchaser of its products. All Norm Engineering products are designed to ensure the highest standards, reliability, and performance.

Norm Engineering Pty Ltd warrants hydraulic cylinders against defects in manufacture for a period of twelve months from date of sale by the dealer or Norm Engineering Pty Ltd to the end consumer. The warranty in relation to hydraulic cylinders ceases upon the occurrence of damage to the piston rod of the hydraulic cylinder.

No warranty applies to hoses, tubes, and fittings in relation to any of the products.

Norm Engineering Pty Ltd warrants all its other products against defects in manufacture for a period of twelve months from the date of sale by the dealer or Norm Engineering Pty Ltd to the end consumer.

Norm Engineering Pty Ltd will, subject to the terms of this warranty, in relation to defective goods:

- a) replace the defective goods at no cost to the end consumer; or
- b) repair the defective goods at no cost to the end consumer; or
- c) pay the cost of having the defective goods repaired.

Norm Engineering Pty Ltd will, subject to the terms of this warranty, in relation to defective services:

- a) supply the services again to the end consumer at no cost to the end consumer; or
- b) pay the cost of having the service supplied again to the end consumer.

Warranty claims may be sent either to Norm Engineering Pty Ltd., P.O. Box 178, Mt Ommaney, Qld. 4074 or to the dealer.

All warranty periods shall commence from the date of sale by Norm Engineering Pty Ltd or the dealer to the end consumer. It is the end consumer's responsibility to establish the date of sale of the product to the end consumer by the dealer.

The end consumer may establish the date of sale by producing to Norm Engineering Pty Ltd the dated contract of sale between the end consumer and the dealer with its warranty claim.

If the end consumer is not able to establish the date of sale of the product to the end consumer by the date of its warranty claim, the warranty period shall be deemed to commence from the date of sale of the product by Norm Engineering Pty Ltd to the dealer.

This warranty will not apply if the end consumer does not use the product in accordance with Norm Engineering Pty Ltd's recommendation.

This warranty will not apply if the end consumer does not use products applied or fitted to any machine, equipment, or plant, in accordance with Norm Engineering Pty Ltd's operating recommendation for the product.

This warranty does not apply to any loss or damage caused through consequential neglect. Unless the end consumer indicates to Norm Engineering Pty Ltd prior to purchasing the product that it intends to use the product for a particular purpose, there is no implied warranty that the product will fit for that particular purpose. Ask Norm Engineering for clarification of the intended use is not included in the manual.

Only a dealer authorised in writing, or issued with an order number, by Norm Engineering Pty Ltd may carry out warranty repairs. Prior written approval must be obtained from Norm Engineering Pty Ltd before warranty repairs are carried out. Norm Engineering Pty Ltd will not recognise any warranty claim for reimbursement of repair costs unless the repairs have been carried out by an authorised dealer with prior written approval from Norm Engineering Pty Ltd to carry out the repairs.

Norm Engineering Pty Ltd limits its liability, as follows:

1) Pursuant to Section 68A of the Trade Practices Act 1974, this clause applies in respect of any of the goods or services supplied under this contract which are not of a kind ordinarily acquired for personal, domestic, or household use or consumption, provided that this clause will not apply if the end consumer establishes that reliance on it would not be fair and reasonable.

2) Liability for breach of a condition or warranty implied into this contract by the Trade Practices Act 1974 other than a condition implied by Section 69 is limited:

a) In the case of goods, to any one of the following as determined by Norm Engineering Pty Ltd:

i. the replacement of goods

ii. the repair of the goods

iii. the payment of the cost of having the goods repaired, excluding travelling and freight charges.

b) In the case of services, to any one of the following as determined by Norm Engineering Pty Ltd.

i. the supplying of the services again; or

ii. the payment of the cost of having the services supplied again

Expenses incurred by the end consumer in connection with making a warranty claim shall be borne by the end consumer unless otherwise agreed by Norm Engineering Pty Ltd.

To the extent permitted by law, all implied conditions, and warranties in the contract of sale between Norm Engineering Pty Ltd and the end consumer are hereby excluded.

The benefits conferred by this warranty on the end consumer are in addition to all other legal rights and remedies that the end consumer has in respect of the products.

Contracts of sale for products, and this warranty are submitted to the exclusive jurisdiction of the courts of Queensland.



## WARRANTY NOTICE

**DEALER:** .....

STATE: ..... SIGNED: .....

**END CONSUMER:**

NAME: .....

ADDRESS: .....

.....

.....

STATE: ..... POSTAL CODE: .....

PHONE: ..... SIGNED: .....

DATE OF SALE TO THE END CONSUMER: ...../...../.....

DESCRIPTION OF PRODUCTS: .....

.....

.....

.....

SERIAL NO: .....

DELIVERY DOCKET NO: .....

DELIVERY DATE: ...../...../.....

**NOTE: THIS FORM IS TO BE COMPLETED BY THE DEALER**

**AND RETURNED TO: NORM ENGINEERING - P O BOX 178**

**MT OMMANEY, BRISBANE, QUEENSLAND, AUSTRALIA, 4074**